

TECHNICAL MANUAL

INSTALLATION

HALF LOOP ANTENNA (HLA) 125



Proprietary Notice

The information contained in this document is proprietary to Elbit Systems Ltd. Use or transfer of this document or the information contained herein without the express written consent of Elbit Systems Ltd. is prohibited. Finders of this document are required to forward it to the nearest police station.

TECHNICAL MANUAL

INSTALLATION

HALF LOOP ANTENNA (HLA) 125



Proprietary Notice

The information contained in this document is proprietary to Elbit Systems Ltd. Use or transfer of this document or the information contained herein without the express written consent of Elbit Systems Ltd. is prohibited. Finders of this document are required to forward it to the nearest police station.

Produced by Elbit Systems Customer Training and Knowledge Services.

© All Rights Reserved, Elbit Systems Ltd.

LIST OF EFFECTIVE PAGES

NOTE: The portion of the text affected by the changes is indicated by a vertical line in the outer margins of the page.
Changes to illustrations are indicated by miniature pointing hands, shading, or legend.

Dates of issue for original and changed pages are:

Original . . . 0 . . . 15 June 2011

TOTAL NUMBER OF PAGES IN THIS PUBLICATION IS 62 CONSISTING OF THE FOLLOWING:

Page No.	*Change No.
Title.....	0
A.....	0
a.....	0
b Blank.....	0
i - vii.....	0
viii Blank.....	0
1-1 - 1-17.....	0
1-18 Blank.....	0
2-1 - 2-32.....	0

(*) Zero indicates an original page.

Table I. ECP/ECO/FCO CONFIGURATION CONTROL

No.	ECP/ECO/ FCO No.	Date	Class	ECP/ECO/FCO SUMMARY	Affected LRU/SYSTEM	Affected LRU/SRU Part No.	Implemented in this Manual Y/N

TABLE OF CONTENTS

Title	Page
How to use this Manual.....	iv
List of Abbreviations.....	v
Foreword	vi
CHAPTER 1 - GENERAL DESCRIPTION	
1.1 Scope.....	1-1
1.2 Overview.....	1-1
1.2.1 Functions.....	1-2
1.2.2 HLA Tuner and Antennas Advantages.....	1-2
1.2.3 Physical Description	1-3
1.2.3.1 HLA-125 Tuner.....	1-3
1.2.3.2 Mounting Tray	1-4
1.3 Antenna Configurations	1-5
1.3.1 HLA R-1M Antenna.....	1-6
1.3.2 HLA Sufa Antenna.....	1-7
1.3.3 HLA Shelter Antenna.....	1-8
1.3.4 HLA Telescopic Antenna.....	1-9
1.3.5 HLA Shipboard Antenna	1-10
1.4 Radiation Pattern.....	1-11
1.5 Theory of Operation	1-15
1.5.1 General Block Diagram	1-15
1.6 Technical Data.....	1-17
CHAPTER 2 - INSTALLATION	
2.1 Scope.....	2-1
2.2 HLA-125 Tuner and HLA R-1M Antenna Installation.....	2-1
2.2.1 Required Equipment	2-1
2.2.2 Installation Procedure	2-2
2.2.2.1 Preparation for Installation.....	2-2
2.2.2.2 Tuner Installation.....	2-3
2.2.2.3 Antenna Connection	2-6
2.2.2.4 Antenna Installation.....	2-8
2.2.2.5 RT Connection	2-11
2.3 HLA-125 Tuner and HLA Shelter Antenna Installation.....	2-12
2.3.1 Required Equipment	2-12
2.3.2 Installation Procedure.....	2-12
2.3.2.1 Preparation for Installation.....	2-12
2.3.2.2 Mountings Installations.....	2-14
2.3.2.3 Antenna Connection	2-16
2.3.2.4 Antenna Installation.....	2-19
2.3.2.5 Tuner Installation.....	2-20
2.3.2.6 Tuner Connection.....	2-21
2.3.2.7 RT Connection	2-22
2.4 HLA-125 Tuner and HLA Shipboard Antenna Installation.....	2-23

TABLE OF CONTENTS (Continued)

Title	Page
2.4.1	Required Equipment 2-23
2.4.2	Installation Procedure 2-23
2.4.2.1	Preparation for Installation..... 2-23
2.4.2.2	Antenna Connection..... 2-25
2.4.2.3	Antenna Installation 2-27
2.4.2.4	Mountings Installations 2-28
2.4.2.5	Tuner Installation..... 2-29
2.4.2.6	Tuner Connection 2-30
2.4.2.7	RT Connection 2-31
2.5	Operational test..... 2-32

LIST OF ILLUSTRATIONS

Figure	Title	Page
1-1	HLA-125 General Description 1-1	
1-2	HLA-125 Tuner External View..... 1-3	
1-3	Mounting Tray External View..... 1-4	
1-4	HLA R-1M Antenna General View 1-6	
1-5	HLA Sufa Antenna General View 1-7	
1-6	HLA Shelter Antenna General View..... 1-8	
1-7	HLA Telescopic Antenna General View 1-9	
1-8	HLA Shipboard Antenna General View..... 1-10	
1-9	HLA R-1M Antenna Radiation Pattern..... 1-11	
1-10	HLA Shelter Antenna Radiation Pattern..... 1-12	
1-11	HLA Shipboard Antenna Radiation Pattern..... 1-13	
1-12	Compare HLA Antennas Radiation Pattern 1-14	
1-13	General Block Diagram..... 1-16	
2-1	HLA R-1M Antenna Installation 2-2	
2-2	Mounting Tray Installation..... 2-3	
2-3	Grounding Head Bolt Installation..... 2-4	
2-4	HLA Tuner Installation 2-5	
2-5	Antenna Connection 1 2-6	
2-6	Antenna Connection 2..... 2-6	
2-7	Antenna Connection 3..... 2-7	
2-8	Antenna Installation 1 2-8	
2-9	Antenna Installation 2 2-9	
2-10	Antenna Installation 3 2-10	
2-11	HLA Shelter Antenna Installation..... 2-13	
2-12	Antenna Mount Installation..... 2-14	
2-13	Mounting Tray Installation..... 2-15	
2-14	Antenna Beam deployment..... 2-16	
2-15	Upper Beam Connection 2-17	
2-16	Side Beam Connection..... 2-18	

LIST OF ILLUSTRATIONS (Continued)

Figure	Title	Page
2-17	Antenna Installation.....	2-19
2-18	HLA Tuner Installation.....	2-20
2-19	Strip to Tuner Connection	2-21
2-20	Strip to Antenna Connection.....	2-22
2-21	HLA Ship Antenna Installation	2-24
2-22	Antenna Beam Deployment	2-25
2-23	Upper Beam Connection.....	2-26
2-24	Side Beam Connection.....	2-26
2-25	Mounting Tray Installation.....	2-28
2-26	HLA Tuner Installation.....	2-29
2-27	Strip to Tuner Connection	2-30
2-28	Strip to Antenna Connection.....	2-31

LIST OF TABLES

Table	Title	Page
1-1	HLA-125 Tuner External Description.....	1-3
1-2	Mounting Tray External Description.....	1-4

HOW TO USE THIS MANUAL

If you need to review antenna configurations, do the following:

- Read Chapters 1 and their associated figures and tables.

If you need to deploy/fold antenna, do the following:

- Go to chapter 2 - choose the required configuration and follow the procedure step by step.

Relevant illustrations and tables are referenced under the paragraph title in the body of the manual, to direct the reader to illustrations and/or tables which will provide a better understanding of the text.

If this manual is updated in the future, all updated pages must be properly placed in the manual and all old pages must be removed and destroyed.

Always keep this manual close to relevant maintenance workstations and reference it prior to and during maintenance activities including any required testing.

LIST OF ABBREVIATIONS

ALE	Automatic Link Establishment
AVG	Average
HF	High Frequency
HLA	Half-Loop Antenna
NVIS	Near Vertical Incidence Skywave
RT	Radio Transceiver
VDC	Volts Direct Current
VRC	Vehicular Radio Communication
RF	Radio Frequency
RT	Radio Transceiver

FOREWORD

SCOPE OF THIS MANUAL

This manual contains information and data needed for installation of the Half Loop Antenna (HLA) - 125.

ARRANGEMENT OF THIS MANUAL

The chapters in this manual are listed below followed by a brief description.

CHAPTER 1 - GENERAL DESCRIPTION

This chapter provides a general description of the Half Loop Antenna HLA-125 along with technical data and specifications. In addition, it provides its physical description and general block diagram description.

CHAPTER 2 - INSTALLATION

This chapter includes the information required to install the following HLA-125 antennas:

- HLA R-1m.
- HLA Shelter
- HLA Shipboard.

DESIGNATION SYMBOLS

N/A.

WARNINGS, CAUTIONS AND NOTES

The following notations are used when it becomes necessary to place special emphasis on procedures, or call the operator's attention to precautionary measures.

WARNING

An operating procedure, practice and so forth, which if not followed correctly, could result in personal injury or loss of life.

CAUTION

An operating procedure, practice and so forth, which if not followed correctly, could result in damage to, or destruction of equipment.

NOTE

An operating procedure, condition and so forth, which special attention should be paid.

CHAPTER 1

GENERAL DESCRIPTION

1.1 SCOPE

This chapter provides a general description of the Half-Loop Antenna (HLA)-125 along with technical data and specifications. In addition, it provides its physical description and general block diagram description.

1.2 OVERVIEW (See Figure 1-1)

HLA-125 half loop antenna is used for reliable Omni-directional Near Vertical Incidence Skywave (NVIS) High Frequency (HF) communication, for vehicles, naval applications and small area installations.

The HLA-125 operates in the 1.6 to 30 MHz frequency range at 125 watts Average (AVG).

The HLA-125 is connected to MICOM and provides reliable communication at 0 to 300 km Omni-directional or 300 to 1,000 km directional.

The HLA-125 antenna coupler automatically tunes to the radio frequency of the connected Radio Transceiver (RT).

Designed to operate with MICOM radio systems, the HLA-125 provides rapid, fully automatic tuning for all operating modes including Frequency Hopping.



Figure 1-1. HLA-125 General Description

1.2.1 FUNCTIONS

HLA-125 tuner performs the following main functions:

- a. Automatically tunes to the RT radio frequency.
- b. Provides efficient RF power transfer from the radio system to the antenna

1.2.2 HLA TUNER AND ANTENNAS ADVANTAGES

- a. The HLA antenna operates as a magnetic antenna with high and equal current along the radiator.
- b. High elevation angle radiation enables omni-directional NVIS 0-300km operation without skip zone.
- c. The magnetic antenna presents low sensitivity to electrical noise.
- d. The antenna presents up to +10db higher link budget compared to whip antenna for 0-150km range.
- e. Support for Data & Hopping.
- f. Collocation improvement.

NOTE

This manual describes NVIS antennas mainly, but HLA antennas can be also optimally activated for medium and long ranges.

Customers may contact Elbit for consultation regarding the most suitable configuration of the required application.

1.2.3 PHYSICAL DESCRIPTION

Each antenna contains an HLA-125 tuner and antenna.

1.2.3.1 HLA-125 Tuner

(See Figure 1-2 and Table 1-1)

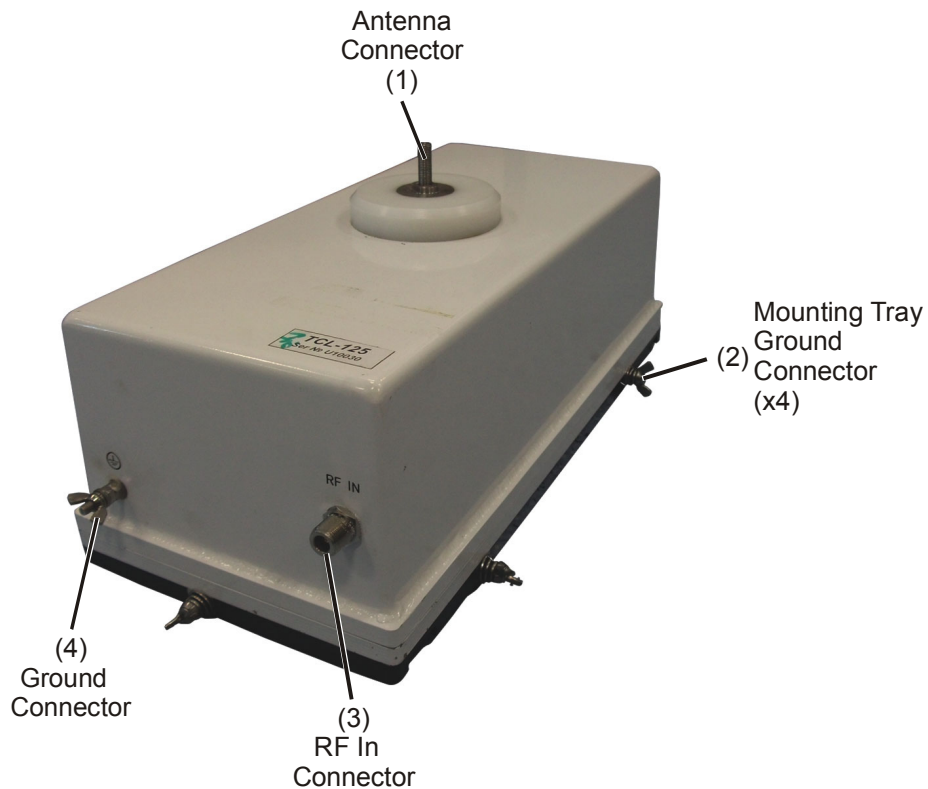

HLA125_TUNER.CDR

Figure 1-2. HLA-125 Tuner External View

Table 1-1. HLA-125 Tuner External Description

No.	Item	Function
1.	Antenna Connector	Connects the radiating elements of the HLA antenna to HLA-125 tuner.
2.	Mounting Tray Ground Connector (x4)	Used as grounding connection to the mounting tray.
3.	RF In Connector	Routes transmitted and received RF signals between the RT and the HLA-125 and all RT control toward the HLA-125 tuner and 12 VDC operational power.
4.	Ground Connector	Optional.

General Description

1.2.3.2 Mounting Tray (See Figure 1-3 and Table 1-2)

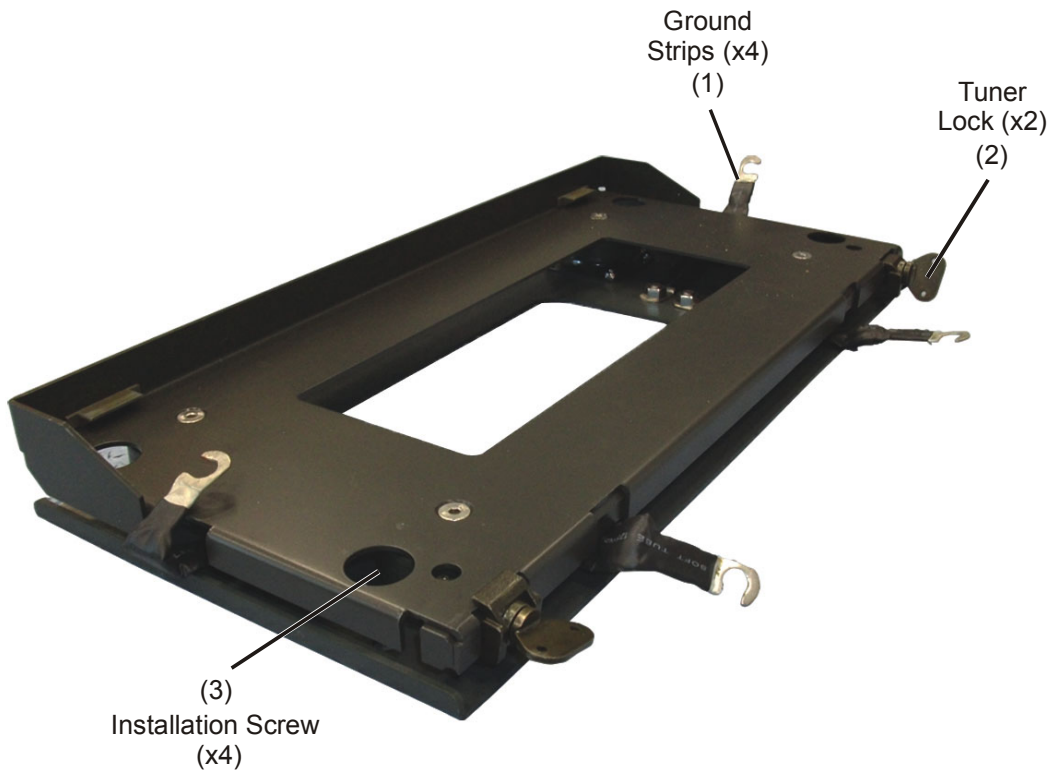

Figure 1-3. Mounting Tray External View

Table 1-2. Mounting Tray External Description

No.	Item	Function
1.	Ground Strip (x4)	Used as grounding connection to the Tuner.
2.	Tuner Lock (x2)	Secures the Tuner to the mounting tray.
3.	Installation Screw (x4)	Sets the mounting tray to the platform roof.

1.3 ANTENNA CONFIGURATIONS

Depending on the platform type, five antennas can be connected to the HLA tuner. The various configurations are as follows:

- HLA R-1M Antenna - Used in smaller vehicles like a jeep.
- HLA Sufa Antenna - Used in larger vehicles like a Sufa.
- HLA Shelter Antenna - Used in shelters.
- HLA Telescopic Antenna - Used in vehicles and shelters.
- HLA Shipboard Antenna - Used in ships.

The principle of the Half Loop antenna is based on producing a high current through a tuned small radiating element and generation the magnetic field by. This magnetic field generates a corresponding electric field in the space.

The configuration is based on the platform of the antenna installation.

1.3.1 HLA R-1M ANTENNA (See Figure 1-4)

The HLA R-1m is installed on a small vehicle and uses the vehicle roof for returning the current to the tuner.

During transmission the antenna conducts current and there is a danger of electrocution.

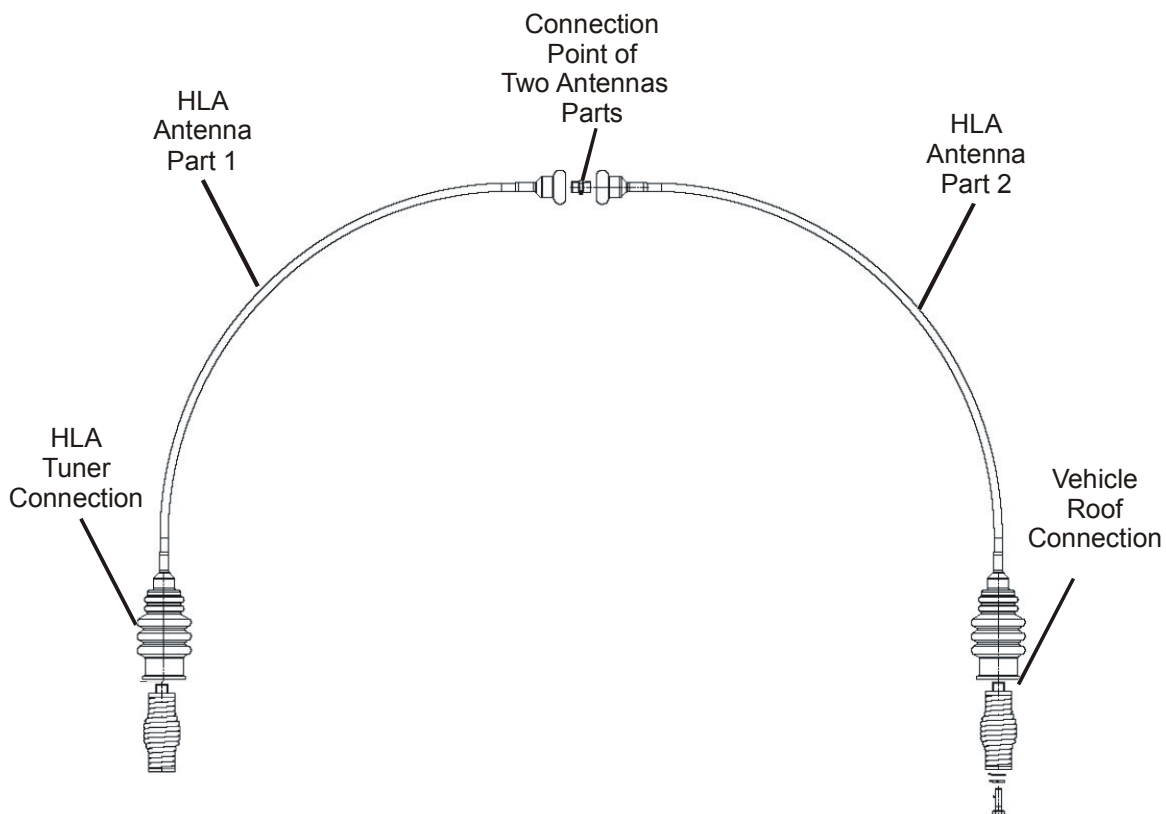

Figure 1-4. HLA R-1M Antenna General View

1.3.2 HLA SUFA ANTENNA

(See Figure 1-5)

The HLA tuner that is installed on a mounting tray connected directly to the antenna using a strip.

The antenna can be folded in a certain way that enables the vehicle to enter low places; but in folded position the RT must be shut off.

During transmission the antenna conducts current and there is a danger of electrocution.

NOTE

Customized antenna dimensions can be ordered.

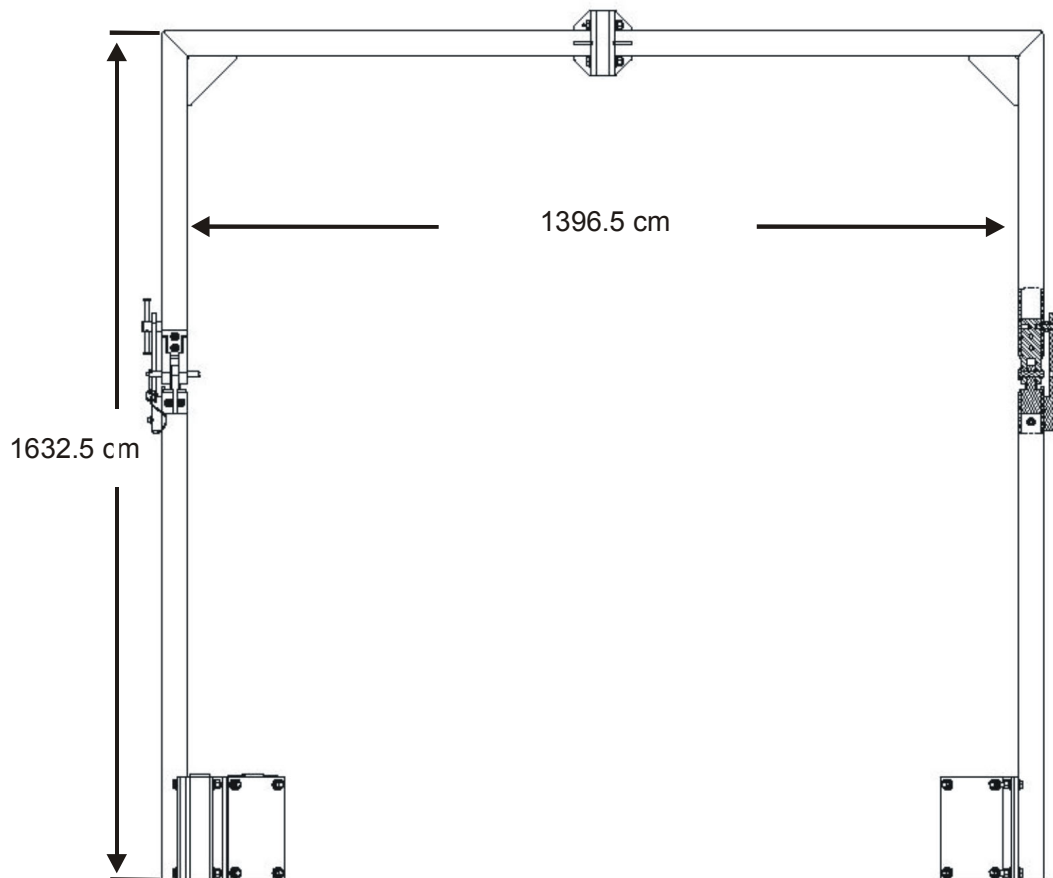

Figure 1-5. HLA Sufa Antenna General View

1.3.3 HLA SHELTER ANTENNA (See Figure 1-6)

The HLA tuner that is installed on a mounting tray connected directly to the antenna using a strip. Antenna mountings are installed on the shelter sides, the antenna is placed on the mountings. The antenna can be folded in a certain way that enables the vehicle to enter low places; but in folded position the RT must be shut off.

During transmission the antenna conducts current and there is a danger of electrocution.

NOTE

Customized antenna dimensions can be ordered.

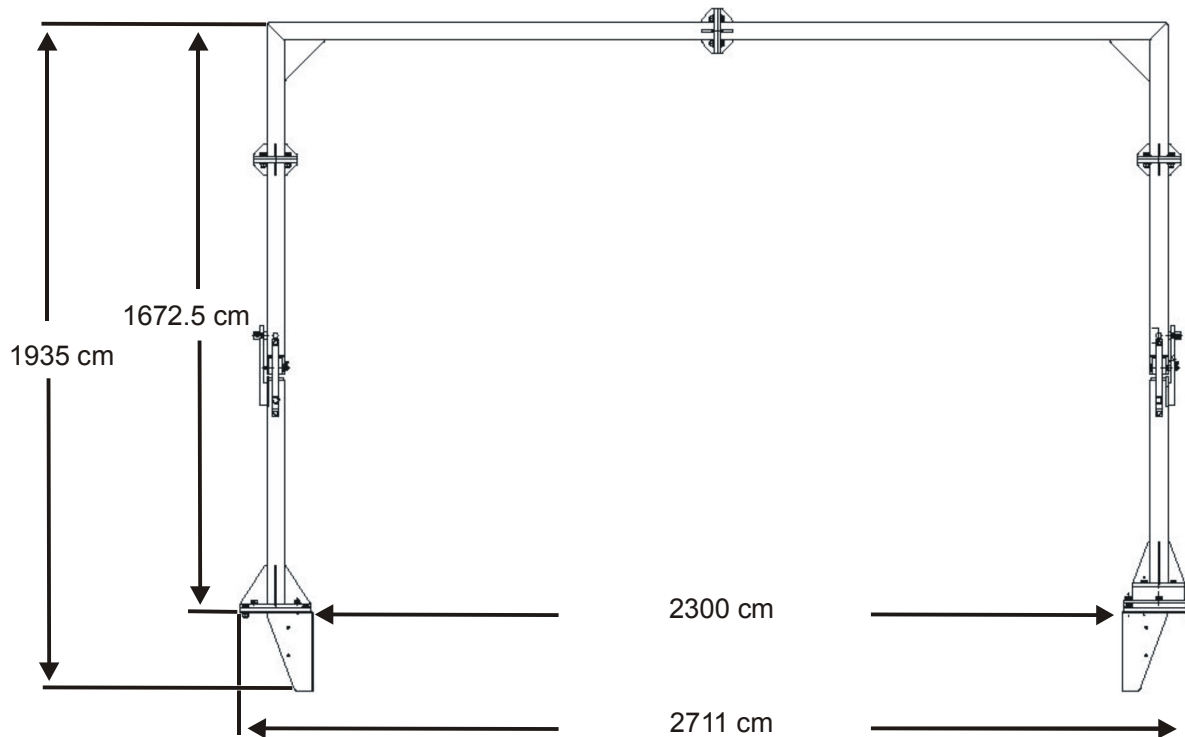

Figure 1-6. HLA Shelter Antenna General View

1.3.4 HLA TELESCOPIC ANTENNA

(See Figure 1-7)

The HLA Telescopic Antenna is similar to the HLA Shelter Antenna, but the telescopic antenna provides diversity in height and width during installation.

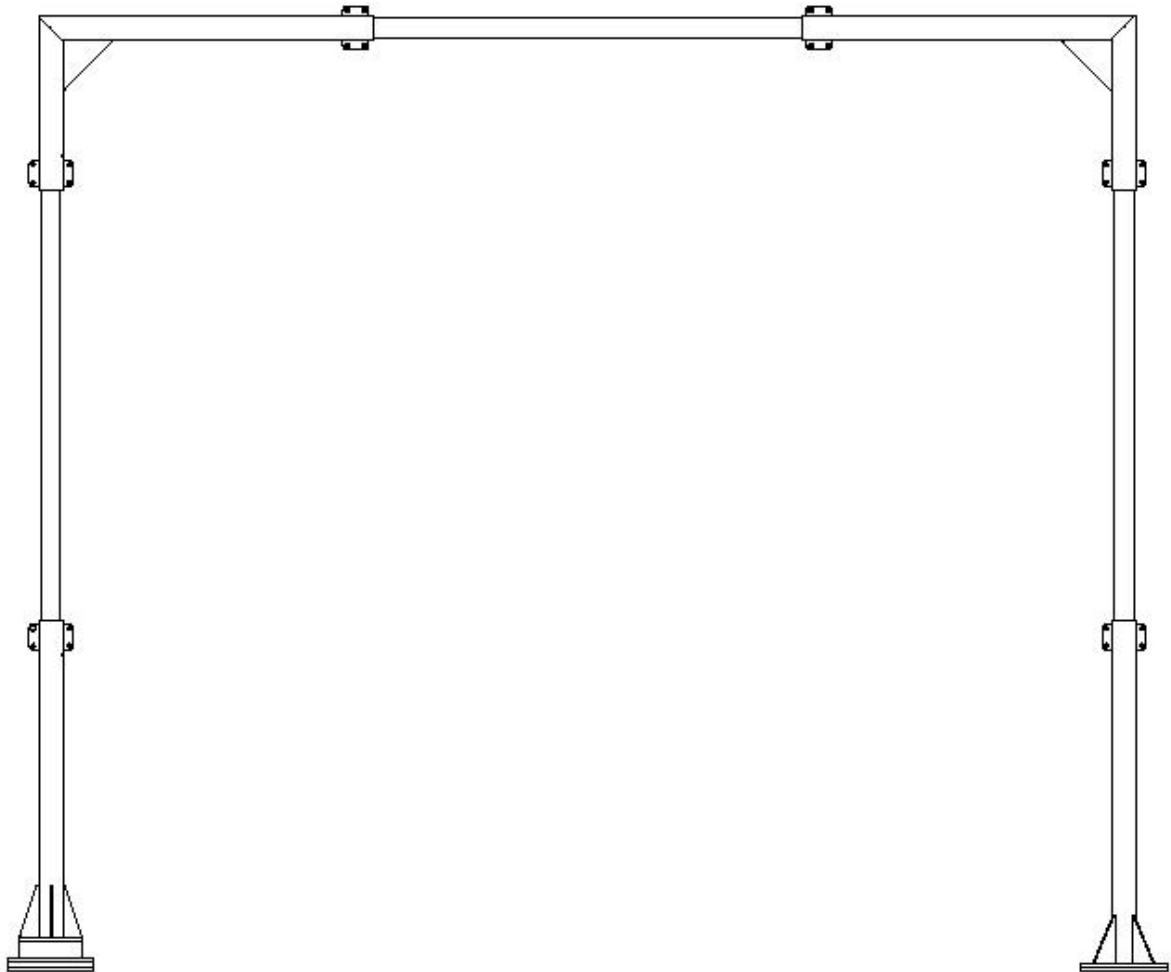

Figure 1-7. HLA Telescopic Antenna General View

1.3.5 HLA SHIPBOARD ANTENNA
(See Figure 1-8)

The HLA Shipboard Antenna is similar to the HLA Shelter Antenna except for the antenna dimensions and angles.

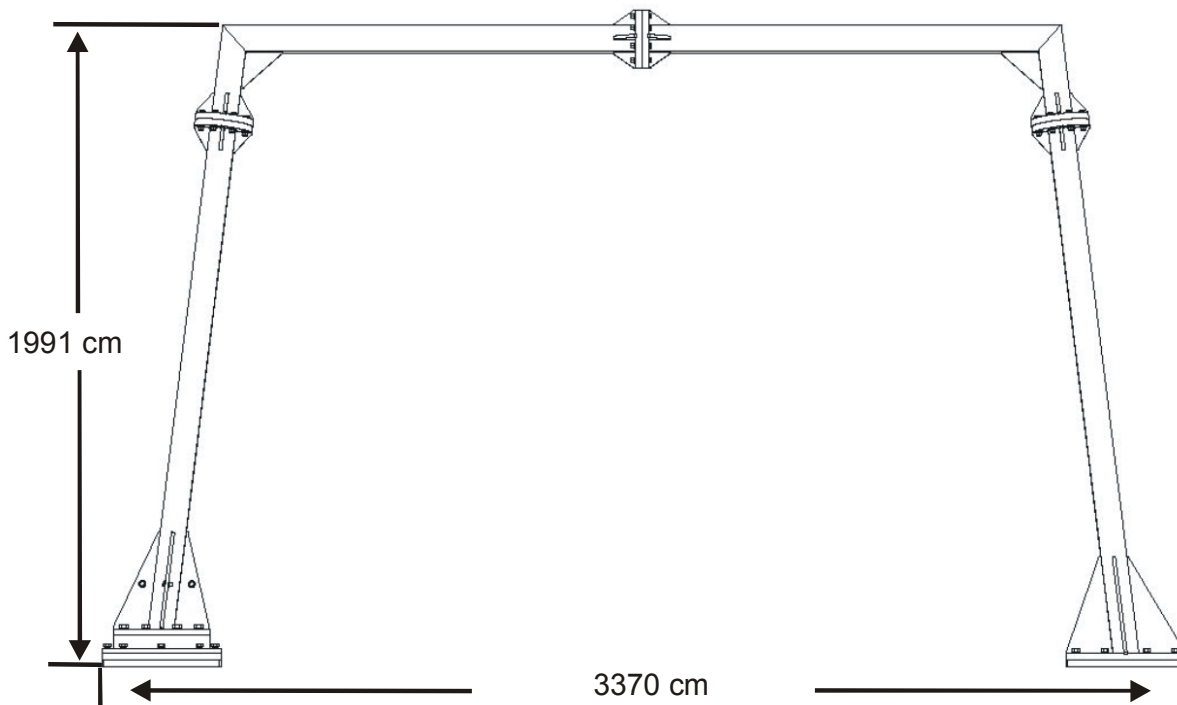

Figure 1-8. HLA Shipboard Antenna General View

1.4 RADIATION PATTERN
 (See Figure 1-9 to Figure 1-12)

The radiation pattern of an antenna is the geometric pattern of the relative field-strengths of the field emitted by the antenna. For an ideal isotropic antenna, this would be a sphere. The radiation pattern of an antenna is typically represented by a three-dimensional graph, or Elevation and azimuth charts.

Above 300 km, the radiation pattern changes to directional, so in order to reach maximum transmitting range, the conducting elements must be installed towards the transmitting direction.

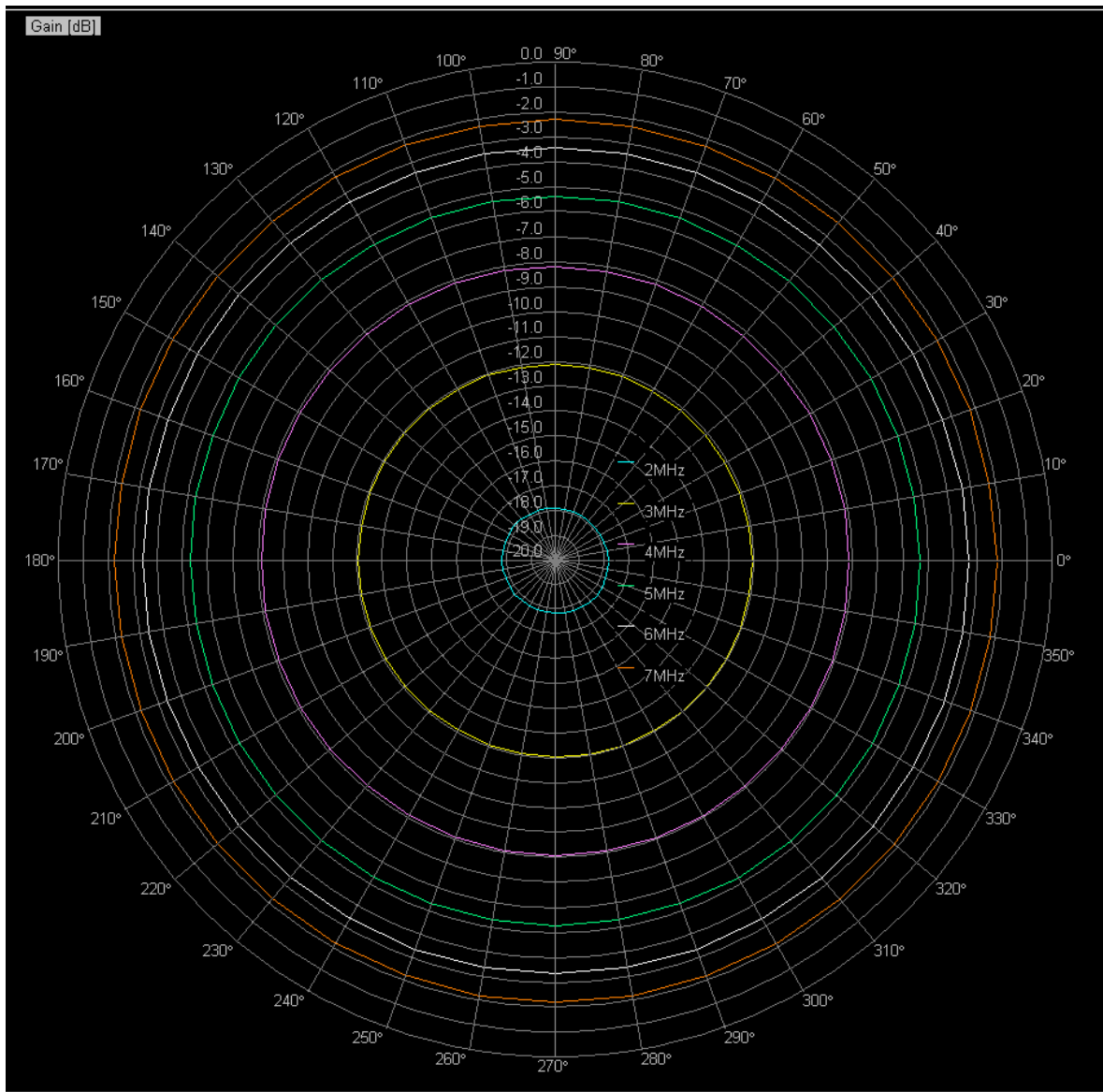

Figure 1-9. HLA R-1M Antenna Radiation Pattern

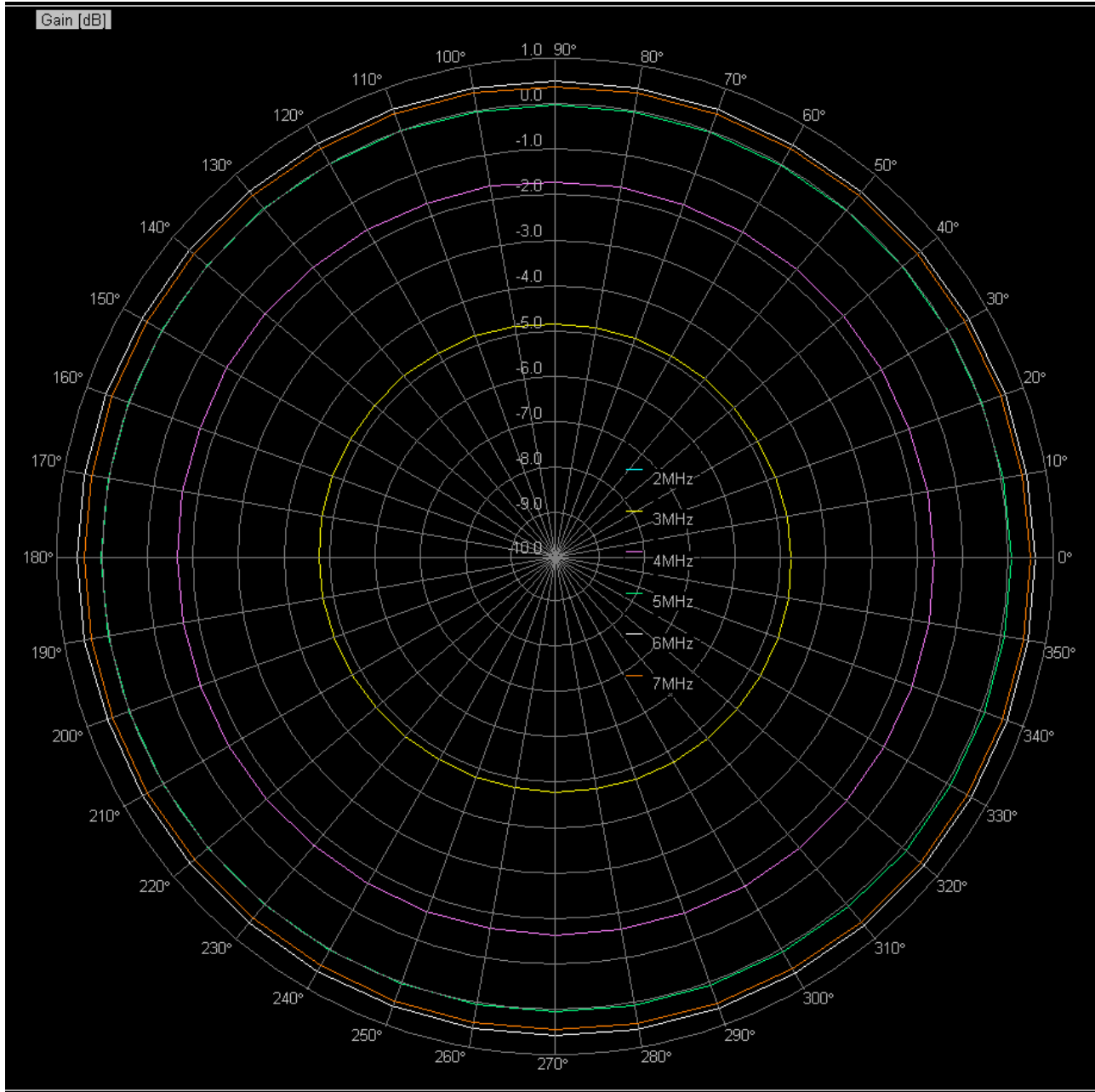

Figure 1-10. HLA Shelter Antenna Radiation Pattern

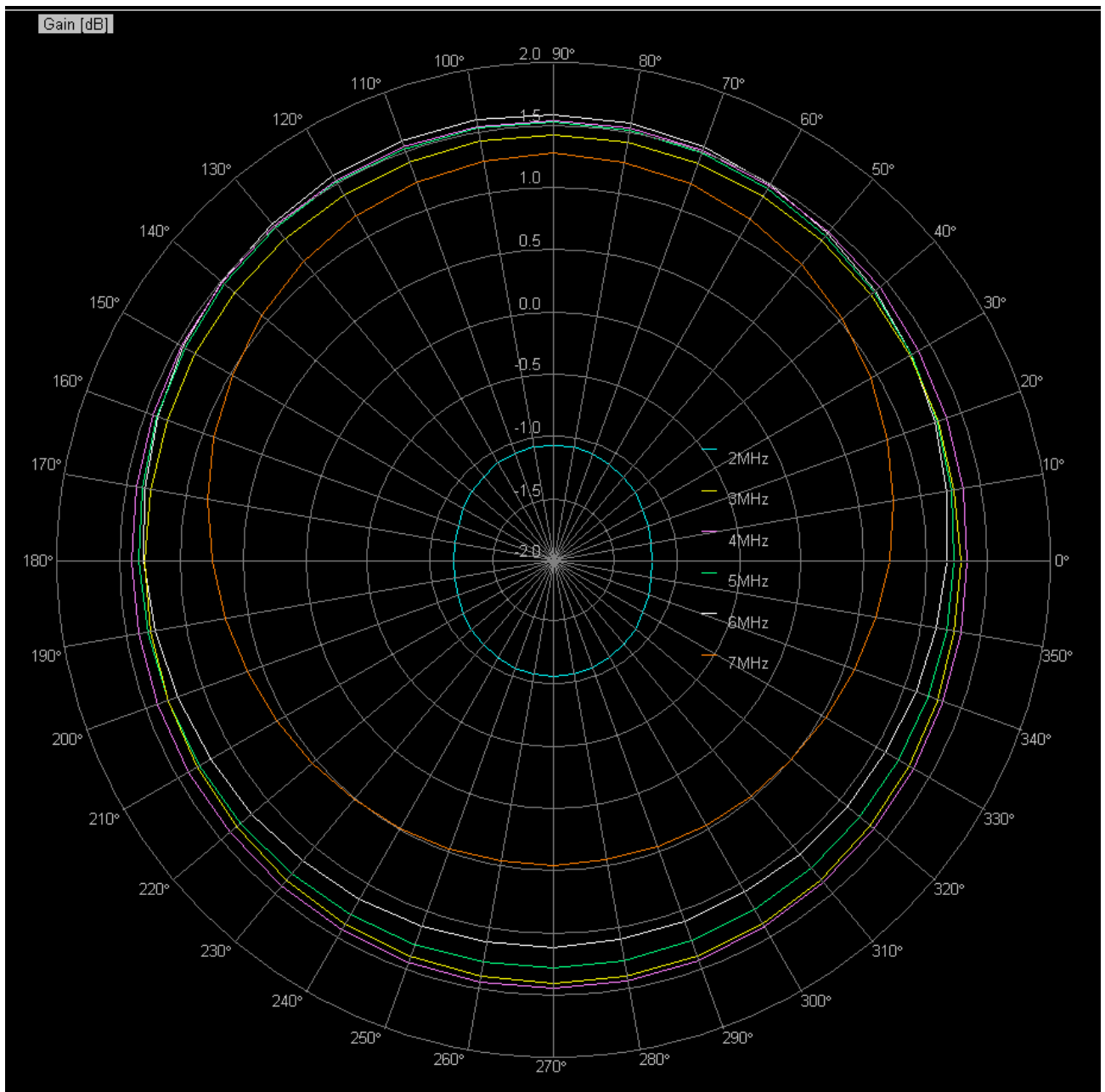

Figure 1-11. HLA Shipboard Antenna Radiation Pattern

General Description

The gain comparison graph of the HLA antennas (without the HLA tuner efficiency) relates to 80 deg Elevation and 90 deg azimuth.

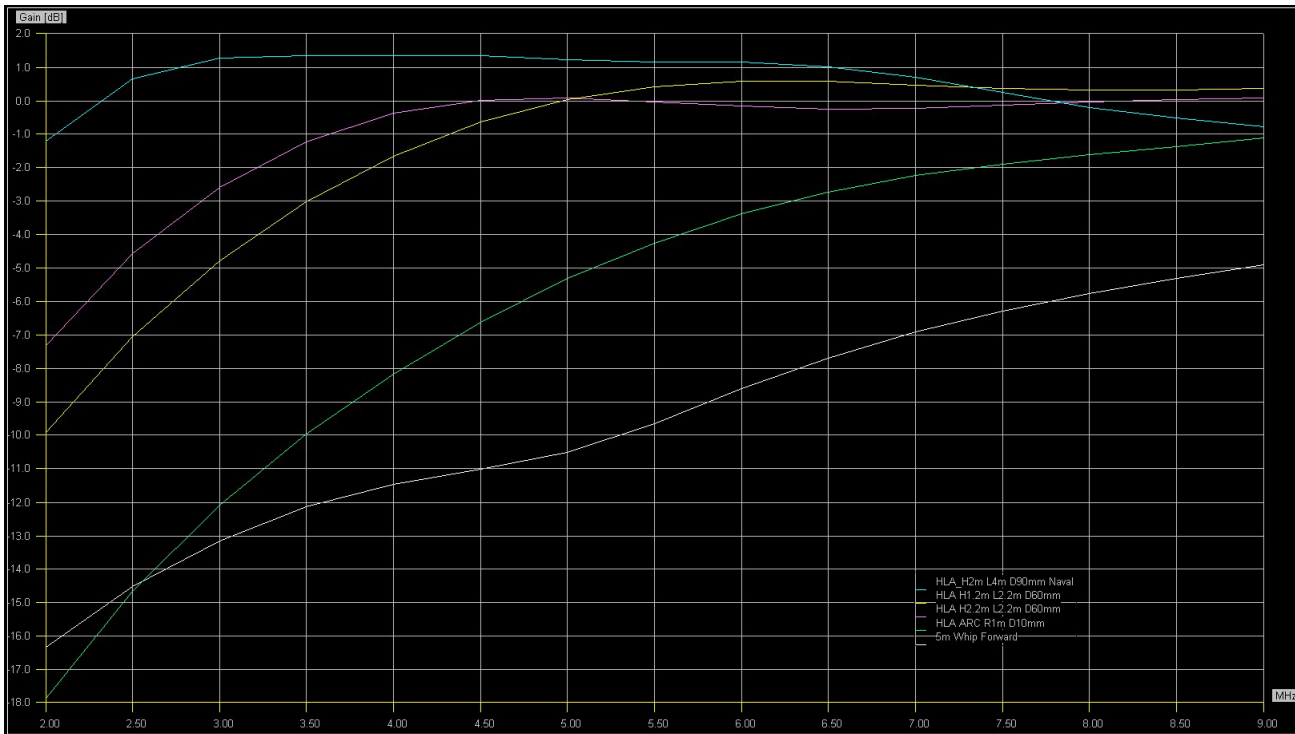

Figure 1-12. Compare HLA Antennas Radiation Pattern

1.5 THEORY OF OPERATION

1.5.1 GENERAL BLOCK DIAGRAM
(See Figure 1-13)

Radio Transceiver (RT) MICOM

Main functions of the RT:

- Generates the transmit signals.
- Demodulates the received signals.
- Processes the GPS signals.
- Controls the radio system operation, provides the interface to the operator, and remotely controls systems.

HLA-125 Tuner

The HLA performs impedance-matching to 50 ohm, so the antenna efficiency in the chosen frequency (between 1.6-30 MHz) will be maximal. The impedance-matching is done using coils and capacitors networks.

Radiating Element

The antenna has one isolated side and one side connected to the ground to create half loop radiating element. The loop is closed using the roof of the platform.

The Half Loop shaped Radiating Element transmits and receives the RF wave.

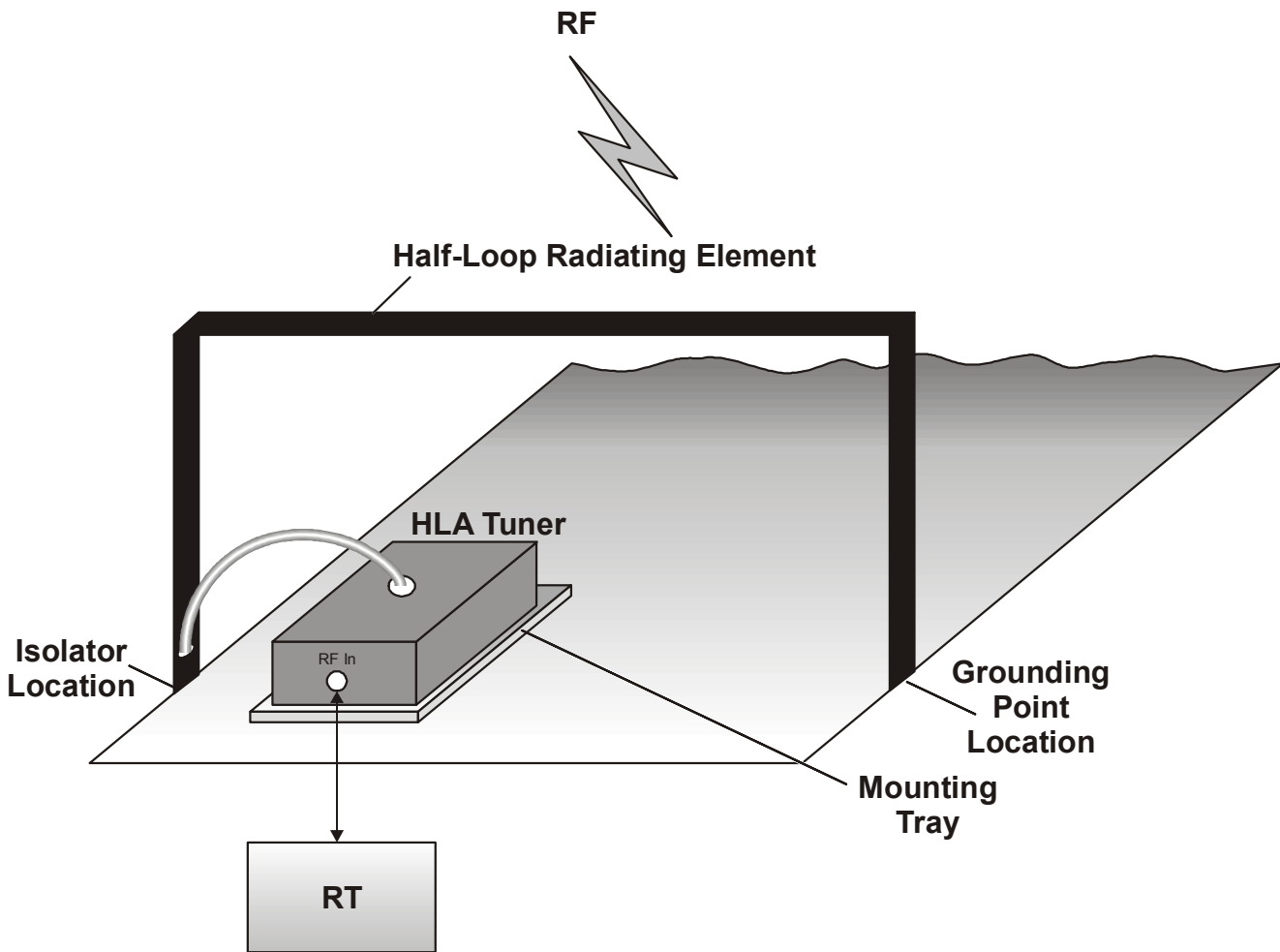

HLA_6125_GBD.CDR

Figure 1-13. General Block Diagram

1.6 TECHNICAL DATA**General:**

Frequency Band	1.6- 30 MHz
Input Power	< 125 W PEP and AVG
Tuned Antenna Input Impedance	50 Ω with VSWR \leq 1.5 for 80% of the frequencies VSWR < 2 for 20% of the frequencies
Azimuth Radiation Pattern	Omni-directional
Tuning Time from Memory	< 5 msec
Tuning RF Power	20 W
Power supply	+28 VDC, current less than 1.2A

Dimensions:

Tuner Dimensions (L, D, H)	506 x 260 x 250mm
Tuner weight	7 kg
Antenna Dimensions:	
Length:	1.5-4m
Height:	1-2m
Width:	10-80mm

Environmental:

Operation Temperature Range	-40 to 65°C
Storage temperature:	-40 to 70°C

CHAPTER 2

INSTALLATION

2.1 SCOPE

This chapter includes information and procedure required to install the following HLA-125 Tuner antennas:

- HLA R-1M Antenna.
- HLA Shelter Antenna.
- HLA Shipboard Antenna.

2.2 HLA-125 TUNER AND HLA R-1M ANTENNA INSTALLATION

2.2.1 REQUIRED EQUIPMENT

No.	Description	Part Number	Quantity
1.	HLA-125 Tuner	2072-09687-10	1
2.	HLA Mounting	2085-46001-00	1
3.	HLA R-1M Antenna	2085-90030-00	1
4.	5 m RF cable (CG-2423) for vehicle	2020-09056-20	1

2.2.2 INSTALLATION PROCEDURE

2.2.2.1 Preparation for Installation

(See Figure 2-1)

- The antenna requires at least two meters of space on the vehicle roof (see Figure 2-1), and thus the tuner location requires planning. Most of the time, the antenna is installed diagonally on the roof.
- The vehicle roof returns the current to the tuner, so the roof has to be made of good conduction materials.
- The connection points between the mounting tray and the roof have to be free of paint.

NOTE

If the roof is not up to the standards mentioned above,
Consult the installation method with the manufacturer.

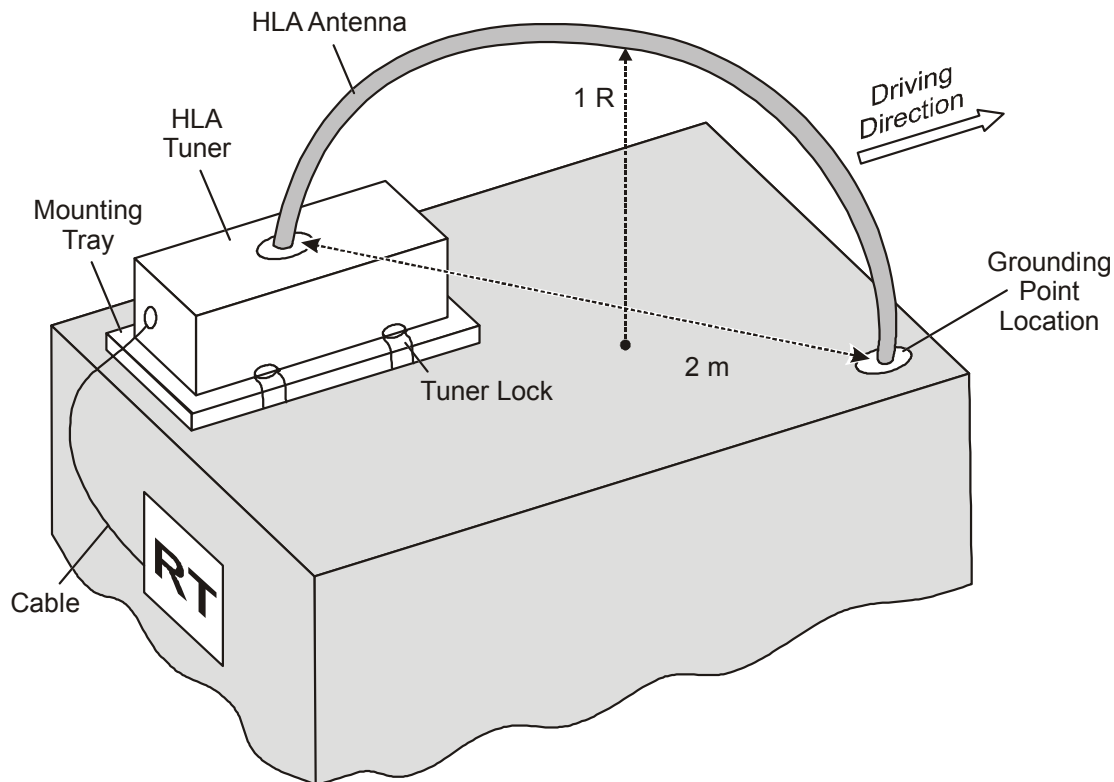

Figure 2-1. HLA R-1M Antenna Installation

2.2.2.2 Tuner Installation
 (See Figure 2-2 to Figure 2-4)

- a. Place the mounting tray on the vehicle roof according to the drawing.
- b. Verify the lock tuner locks are facing towards the center of the vehicle (see Figure 2-1).



Consult the vehicle manufacturer on the proper drilling/welding procedure prior to installation on the vehicle roof.

Failure to comply may result in damage.

- c. Clean the installation area from non conducting materials.
- d. Attach the mounting tray to the vehicle roof using four bolts, spring washers, flat washers and nuts or by welding (see Figure 2-2).

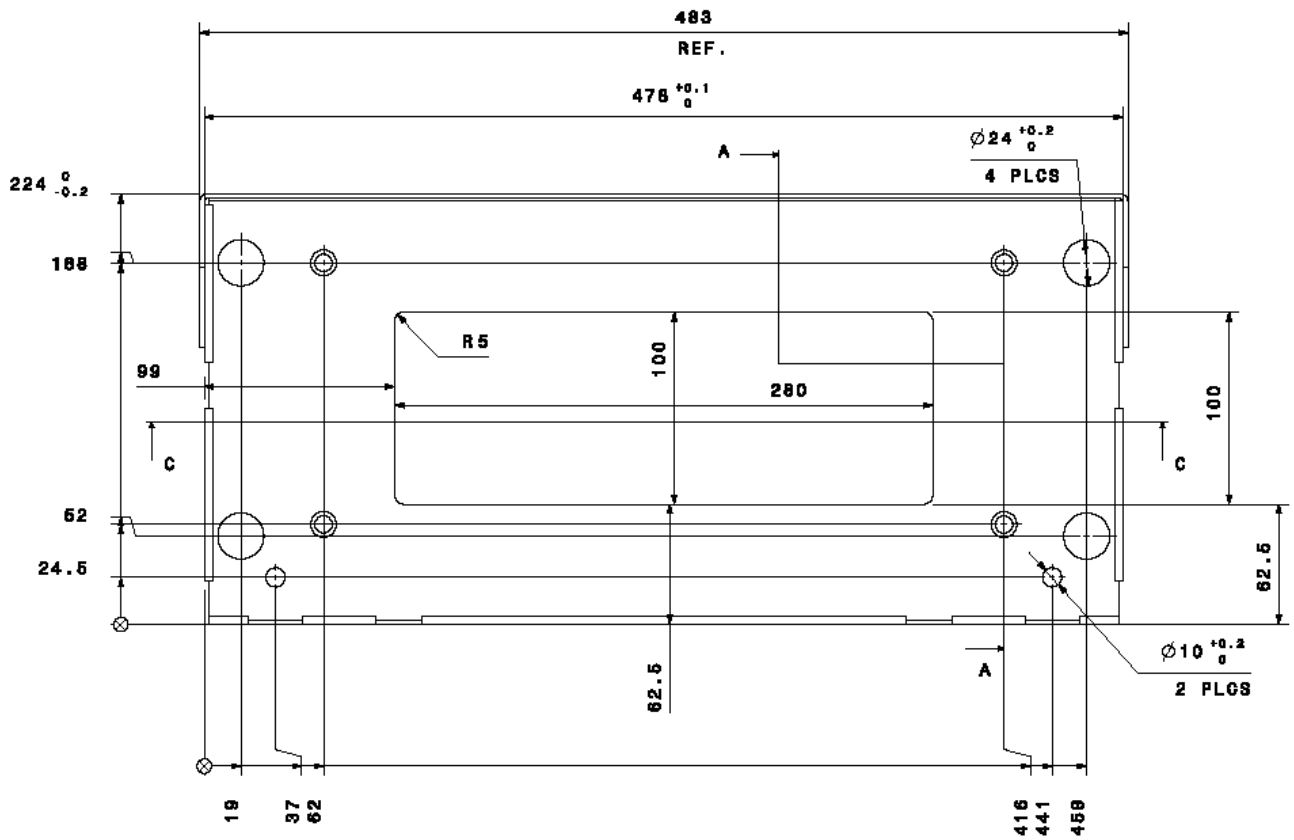

Figure 2-2. Mounting Tray Installation

Installation

- e. Measure two meters diagonally from mounting tray center and mark the grounding point of the antenna (see Figure 2-1).
- f. Clean the grounding point from non conducting materials.
- g. Set the grounding head bolt to the vehicle roof using, spring washers, flat washers and spring or by welding (see Figure 2-3).

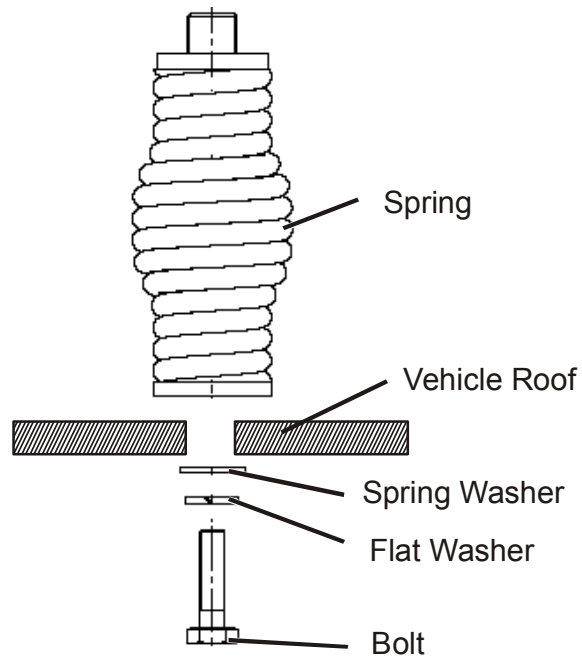

Figure 2-3. Grounding Head Bolt Installation

Place the HLA Tuner on the mounting tray with the HLA tuner connectors facing outside of the vehicle (see Figure 2-1)

- h. Close the two tuner locks (2) to secure the HLA tuner (1) to the mounting tray (5) (See Figure 2-4).
- i. Open four grounding locks (3) installed on the HLA tuner (See Figure 2-4).
- j. Connect four grounding strips (4) located on the mounting tray (5) to the four grounding locks (3) located on the HLA tuner (1), and tighten the grounding locks (See Figure 2-4).



Figure 2-4. HLA Tuner Installation

2.2.2.3 Antenna Connection (See Figure 2-5 to Figure 2-7)

The antenna is built from two parts (quarter arch) and one adapter.

- a. Pull back the spring cover and connect each part to the spring, return the cover.
- b. Place the adapter (1) in the connection nut and tighten the connection nut (see Figure 2-5).

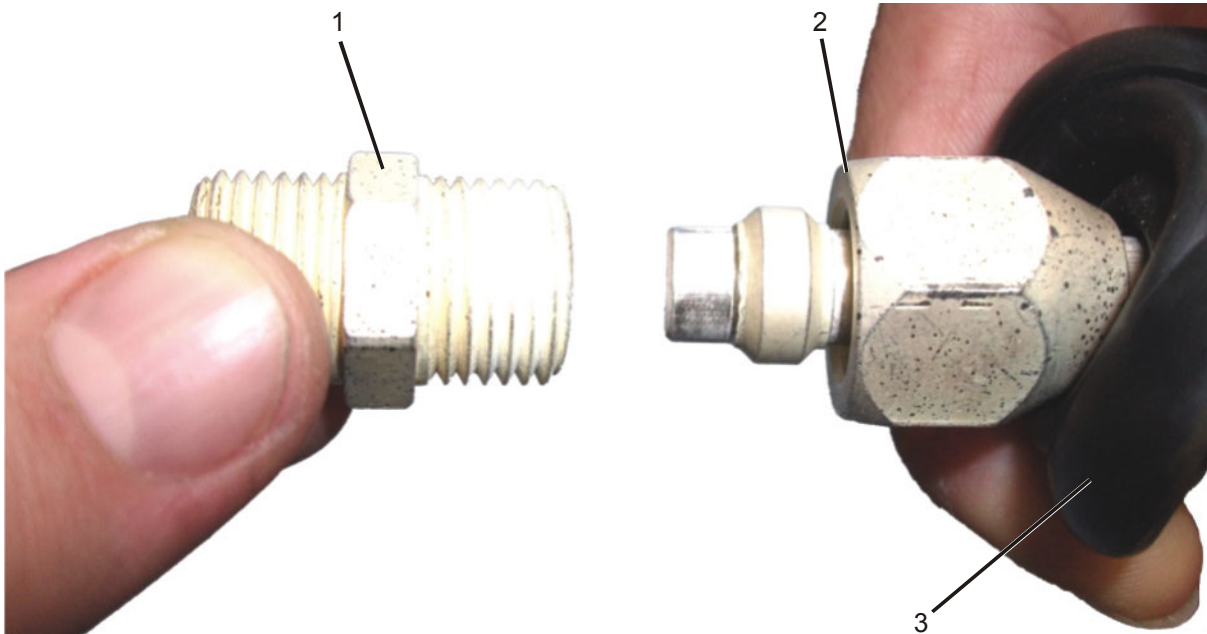

Figure 2-5. Antenna Connection 1

- c. On the second antennas parts, raise the antennas adapter cover, and pull back connection nut.
- d. Connect both antennas parts by connecting the adapter (1) to the second antennas connection nut (see Figure 2-6).

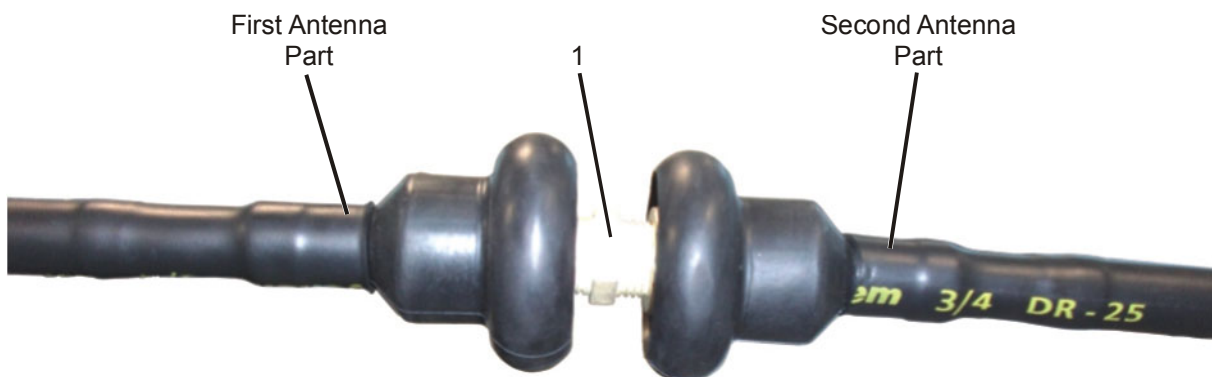

Figure 2-6. Antenna Connection 2

- e. Pull the two connectors covers (4) toward each other to cover the connection point (see Figure 2-7).

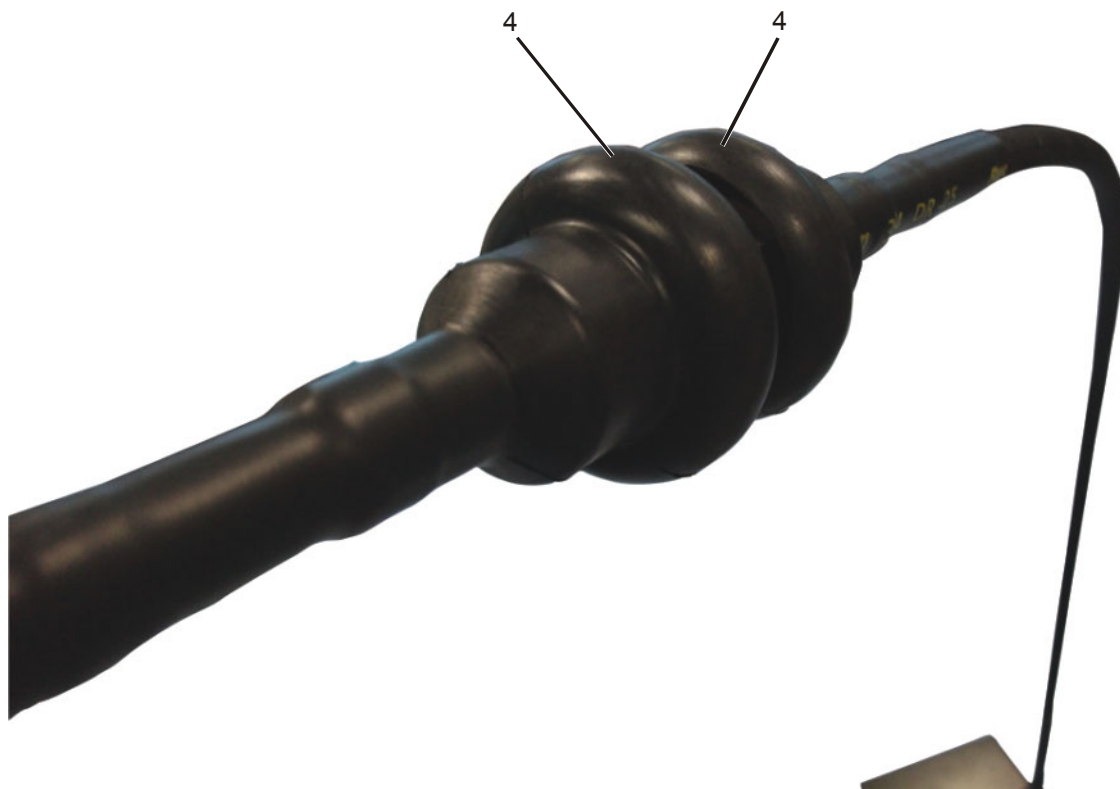

Figure 2-7. Antenna Connection 3

WARNING

Do not remove the rubber cover. The antenna connector is exposed to high voltage during transmission and the rubber cover protects the operator from electrocution.

Failure to comply may result in injury to personnel.

CAUTION

Do not remove the rubber cover. It protects the equipment from short-circuit during rain.

2.2.2.4 Antenna Installation (See Figure 2-8 to Figure 2-10)

- a. Screw a spring (2) on the HLA tuner (1) antenna connector (3) (see Figure 2-8).

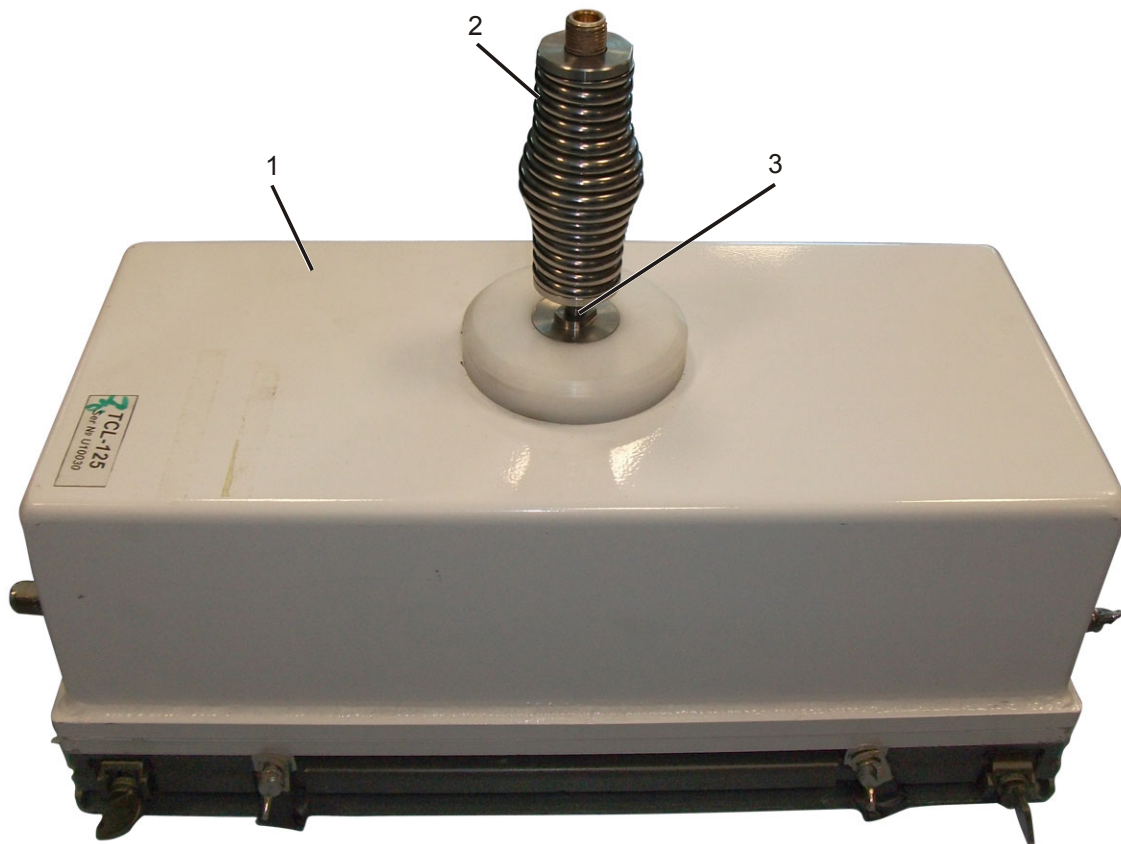

ANTENNA_INSTALL_1.CDR

Figure 2-8. Antenna Installation 1

- b. Pull up the antenna cover (2).
- c. Insert one end of the antenna (1) on the spring (4) and tighten the locking nut (3) (see Figure 2-9).

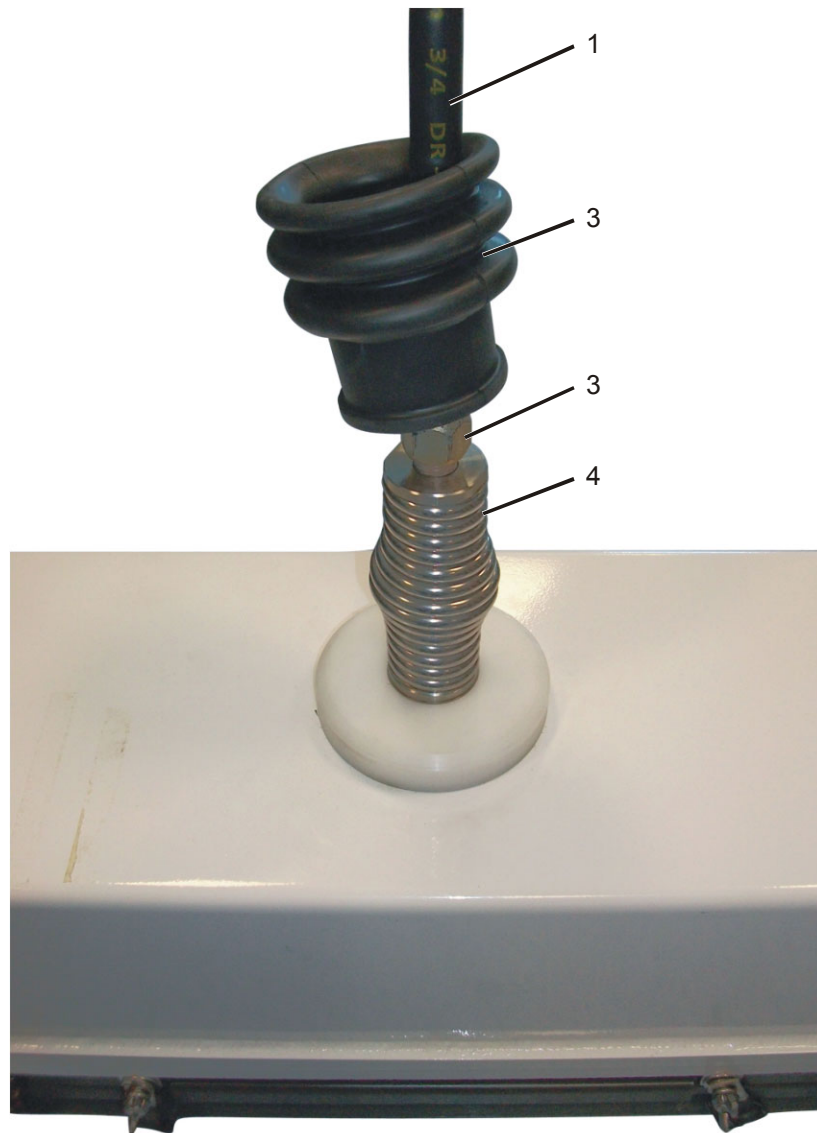

Figure 2-9. Antenna Installation 2

- d. Pull down the antenna cover (1) over the spring to protect the connection (see Figure 2-10).

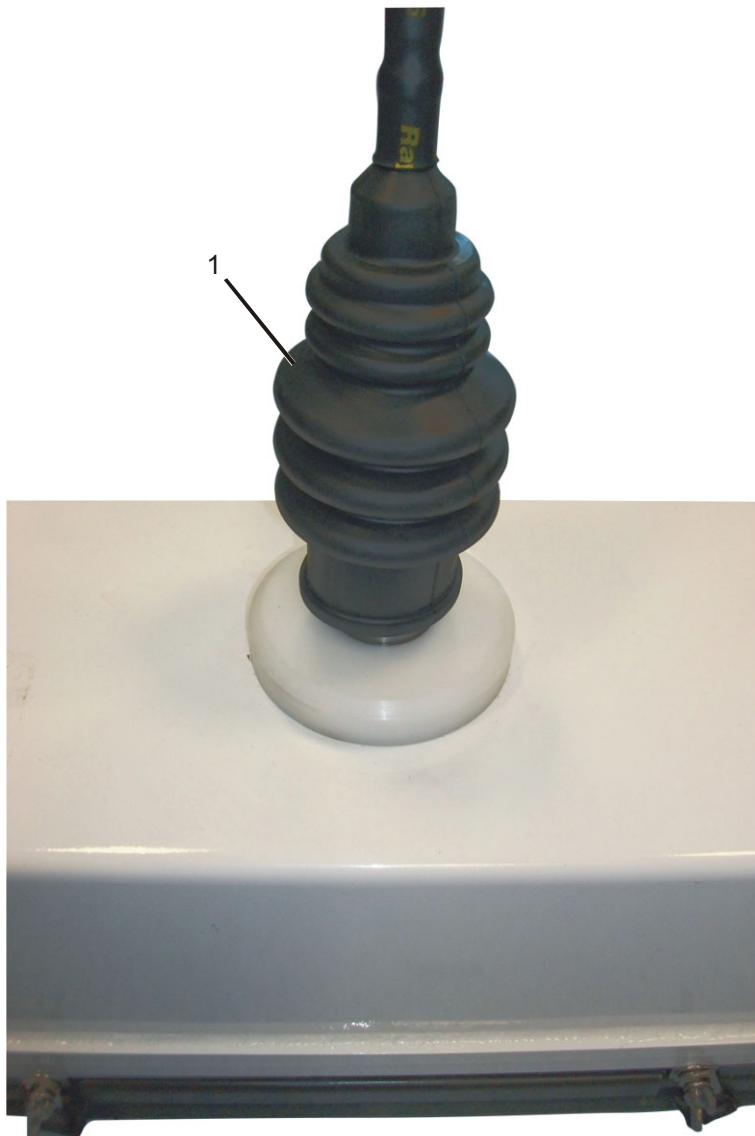

Figure 2-10. Antenna Installation 3

WARNING

Do not remove the rubber cover. The antenna connector is exposed to high voltage during transmission and the rubber cover protects the operator from electrocution.

Failure to comply may result in injury to personnel.

CAUTION

Do not remove the rubber cover. It protects the equipment from short-circuit during rain.

- e. Insert the other end of the antenna on the spring and tighten the locking nut.

2.2.2.5 RT Connection

- a. Connect RF cable connector (CG-2423) to RF connector on the HLA Tuner (see Figure 2-4).
- b. Perform operational test as appears in 2.5

2.3 HLA-125 TUNER AND HLA SHELTER ANTENNA INSTALLATION

2.3.1 REQUIRED EQUIPMENT

No.	Description	Part Number	Quantity
1.	HLA-125 Tuner	2072-09687-10	1
2.	HLA Mounting	2085-46001-00	1
3.	Long Strip	2085-48001-31	1
4.	Rubber cup HLA	2085-43700-00	1
5.	HLA Shelter Antenna	2085-09202-00	1
6.	5 m RF cable (CG-2423) for vehicle	2020-09056-20	1

2.3.2 INSTALLATION PROCEDURE

2.3.2.1 Preparation for Installation (See Figure 2-11)

The antenna creates vertical and horizontal forces during movement of the shelter. There for, before antenna installation, a mechanical planning must be performed to determine the right way to install the antenna to the shelter sides or if the shelter has to have reinforcement by adding support plates.

NOTE

A different length and height of the antenna can be ordered from Elbit, according to the specific shelter dimensions.

For the mechanical design, consults with the shelter manufacturer.

A custom mechanical design and installation can be ordered from Elbit.

- a. Plan the antennas mounts location and the mounting tray location.

NOTE

The distance between the HLA tuner and the isolated leg of the antenna should not exceed 20 cm (the strip length).

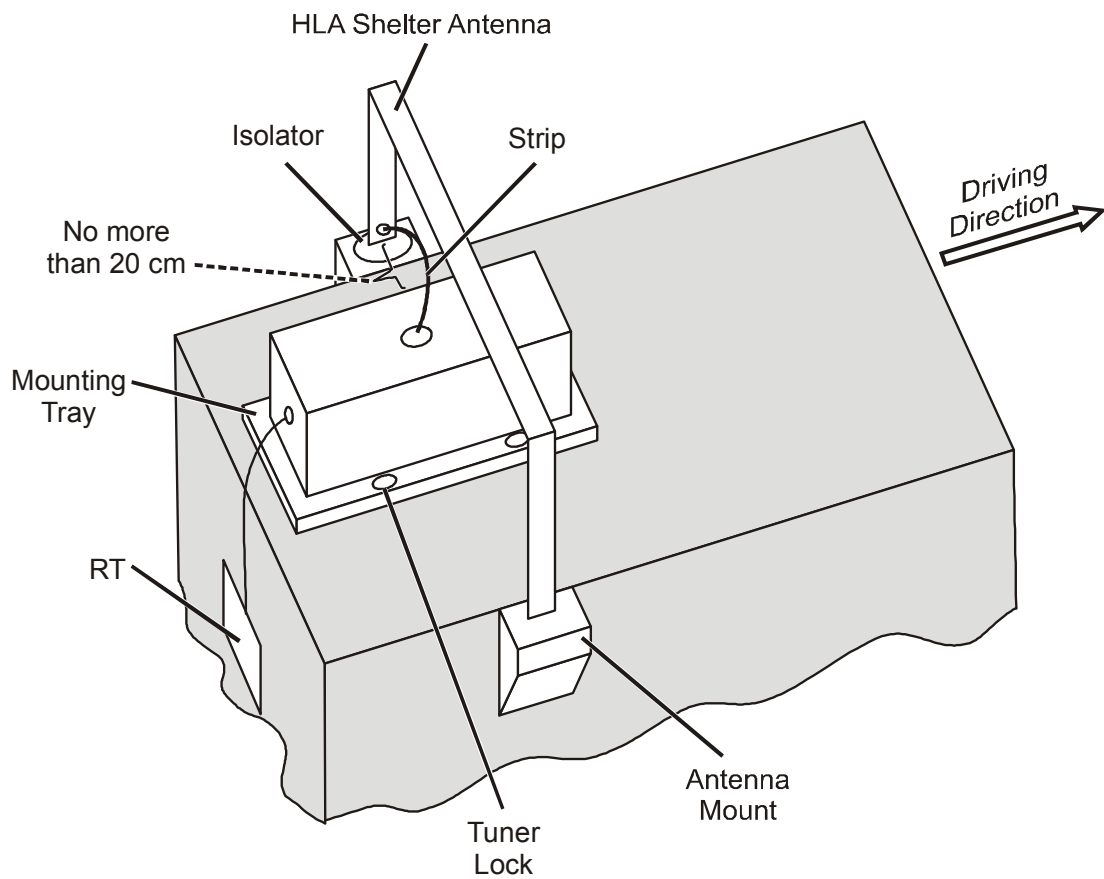

Figure 2-11. HLA Shelter Antenna Installation

2.3.2.2 Mountings Installations (See Figure 2-12 to Figure 2-13)



Consult the shelter manufacturer on the proper drilling/welding procedure prior to installation on the vehicle roof.

Failure to comply may result in damage to equipment.

- a. According to mechanical design, place one antenna mount on the left side of the shelter, and set it using four bolts, spring washers, flat washers and nuts or by welding (see Figure 2-12).
- b. Place the second antenna mount on the right side of the shelter, and attach it using four bolts, spring washers, flat washers and nuts or by welding.

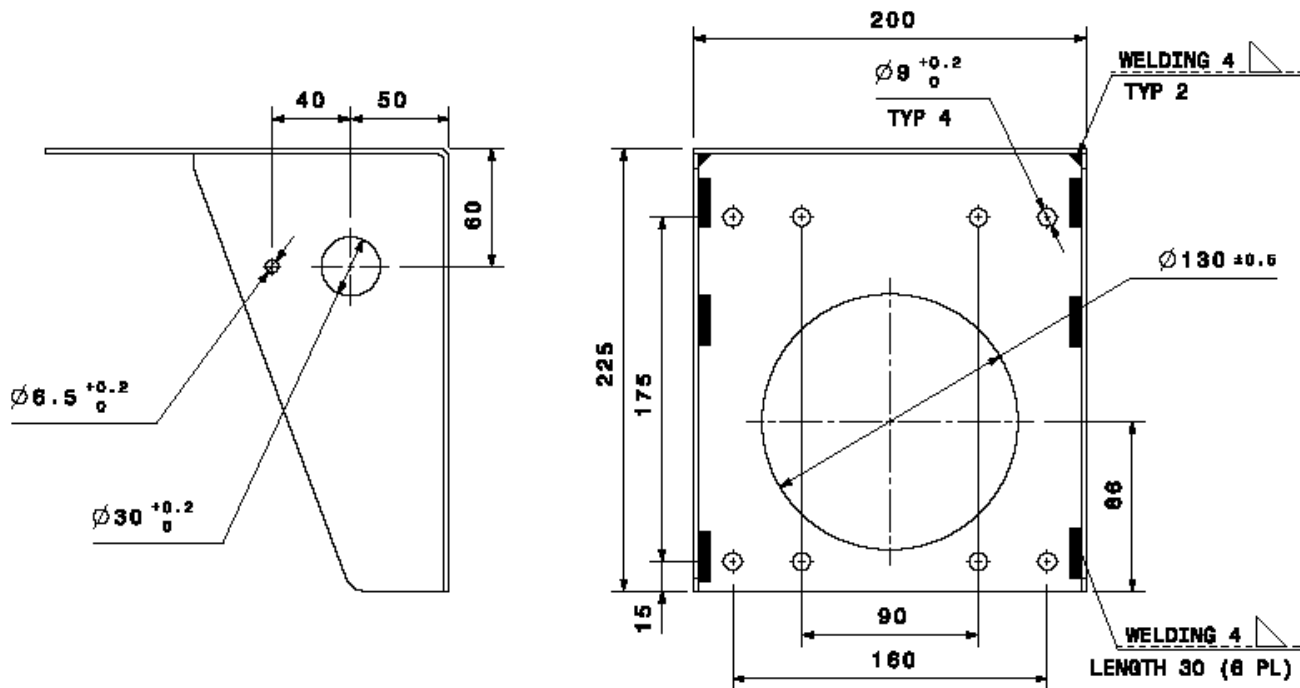

Figure 2-12. Antenna Mount Installation

- c. According to the mechanical design, verify the distance between the mounting tray and the antenna mount does not exceed 20 cm (see Figure 2-11).
- d. Clean the installation area from non conducting materials.
- e. Attach the mounting tray to the vehicle roof using four bolts, spring washers, flat washers and nuts or by welding (see Figure 2-13).
- f. Verify the lock tuner locks are facing towards the center of the shelter (see Figure 2-11).

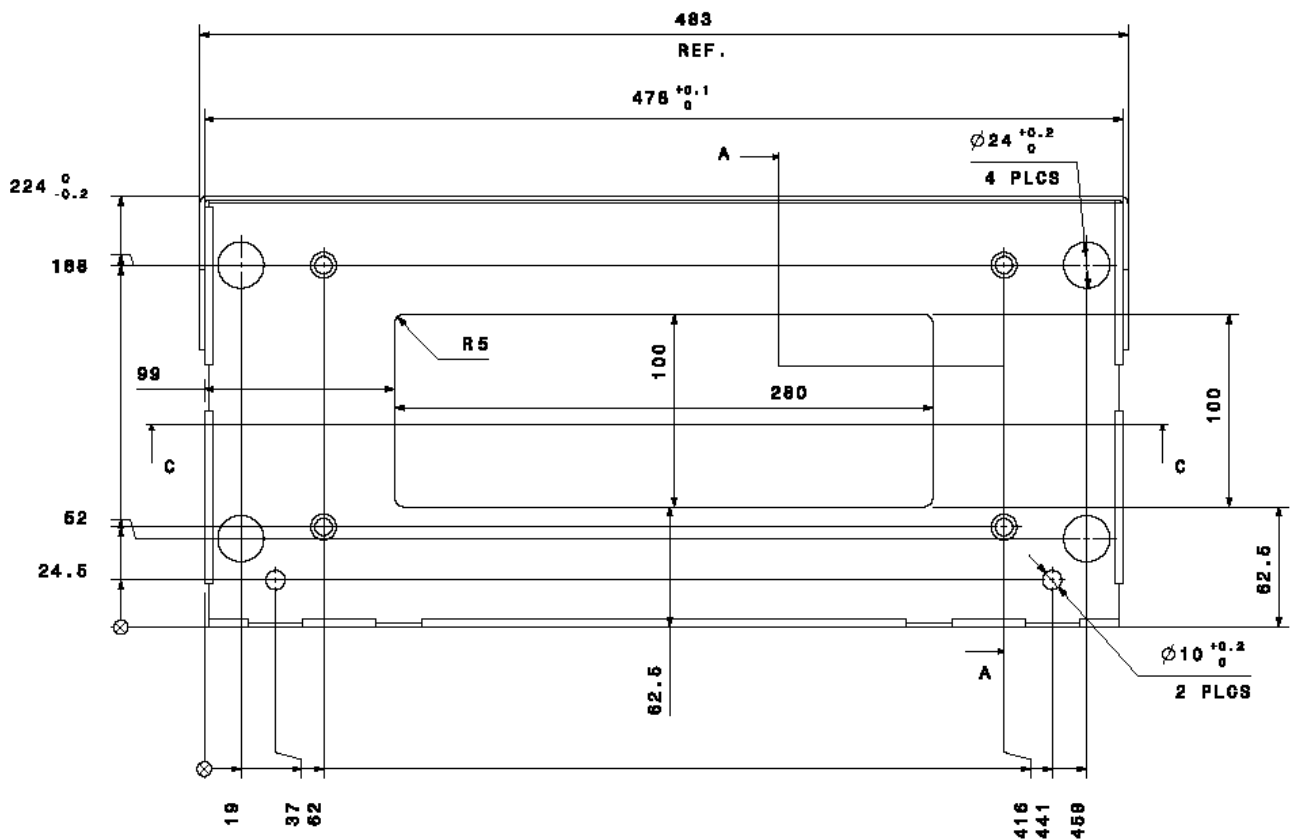

Figure 2-13. Mounting Tray Installation

2.3.2.3 Antenna Connection (See Figure 2-14 to Figure 2-16)

The antenna is built from four parts. Two upper beams and two side beams.

- Place the four parts of the antenna on the ground (See Figure 2-14).
- Verify that the leg with the isolator (2) is placed on the correct side (located near the mounting tray).
- Verify the handle (1) located at each side beam is facing towards the outside (See Figure 2-14).

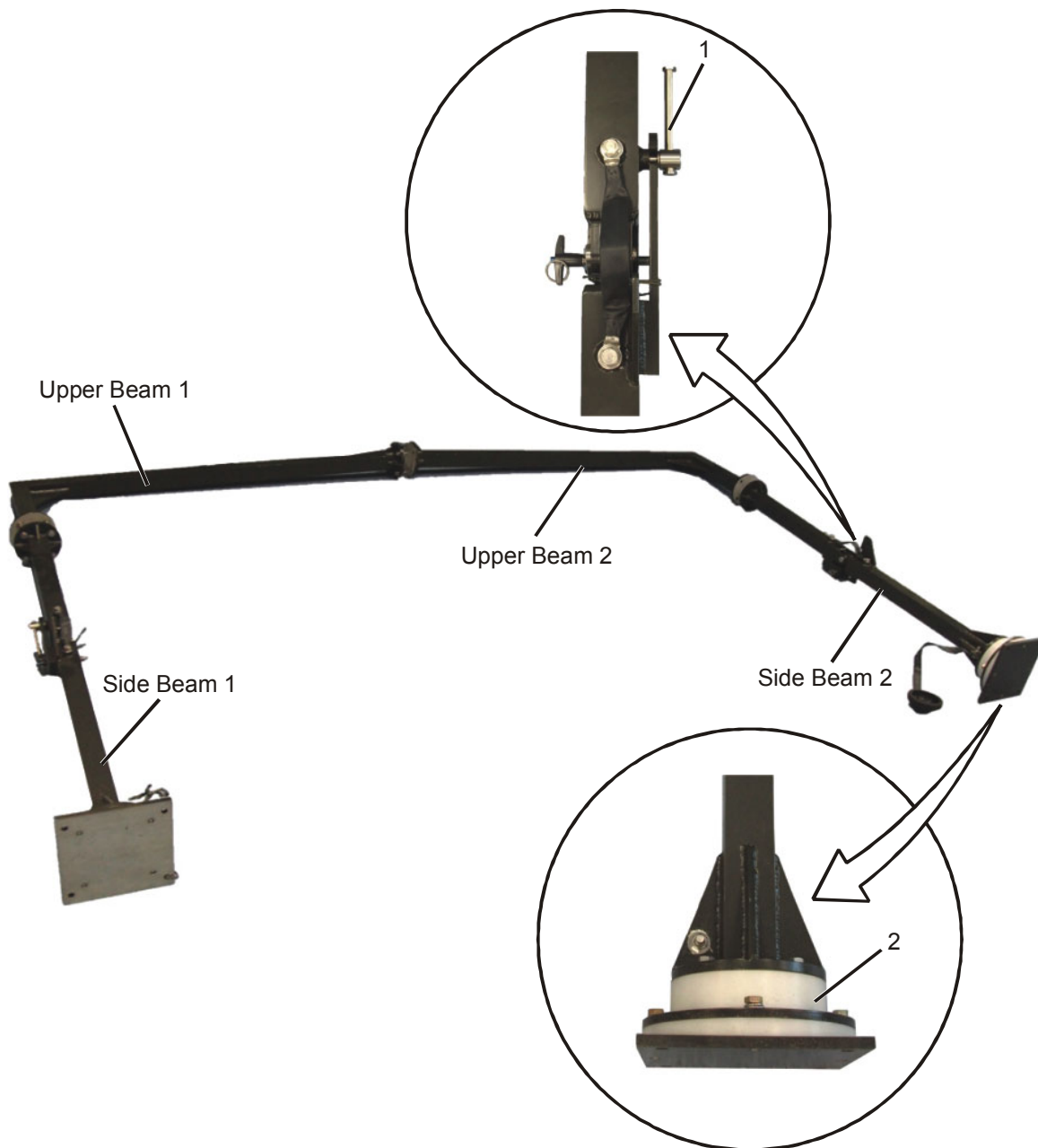

Figure 2-14. Antenna Beam deployment

NOTE

The handle is part of a folding mechanism that enables to fold part of the antenna. The antenna should fold towards the rear part of the shelter.

- d. Connect the two upper beams (1) to each other using four bolts, spring washers, flat washers and nuts (2) (See Figure 2-15).

NOTE

Tighten the bolts in a diagonal pattern to increase the connection force.

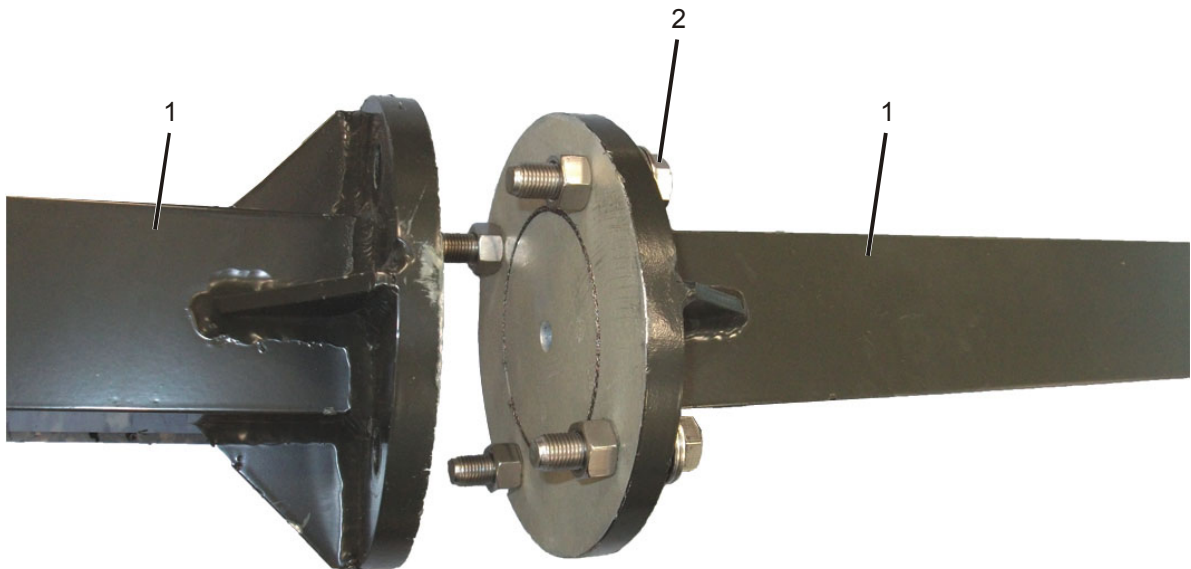

Figure 2-15. Upper Beam Connection

Installation

- e. Connect the left beam (2) to the upper beam (1) using four bolts, spring washers, flat washers and nuts (3) (See Figure 2-16).
- f. Connect the right beam to the upper beam using four bolts, spring washers, flat washers and nuts.

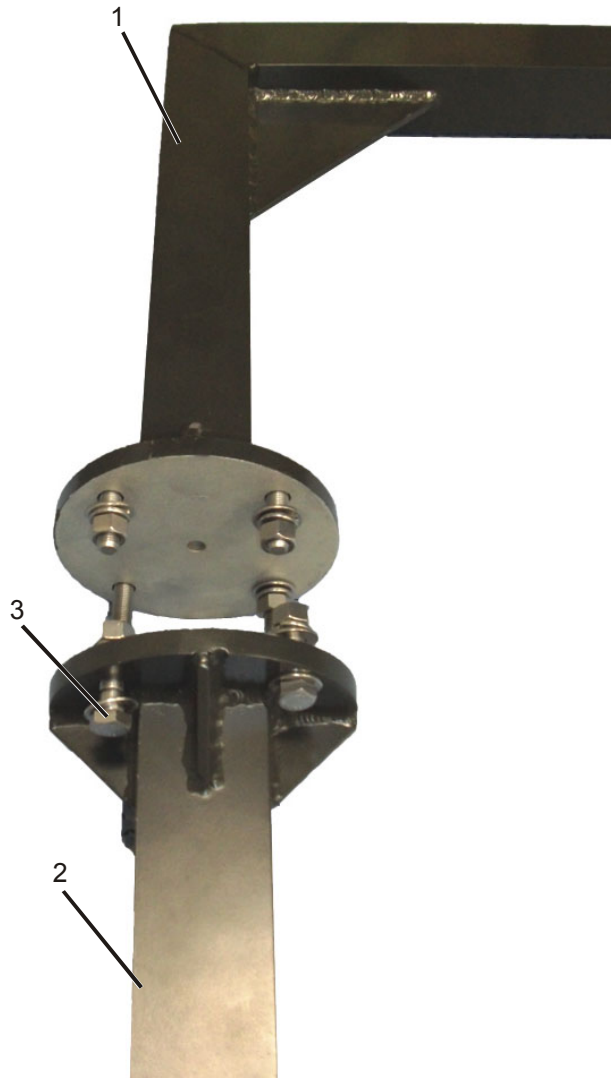

Figure 2-16. Side Beam Connection

2.3.2.4 Antenna Installation

(See Figure 2-17)

- a. Raise the HLA shelter antenna onto the shelter roof.
- b. Place the antenna on the antenna mounting.

NOTE

Verify that the leg with the isolator is placed near the mounting tray.

- c. Connect HLA shelter antenna to the each antenna mounting using four bolts, spring washers, flat washers and nuts (see Figure 2-17).

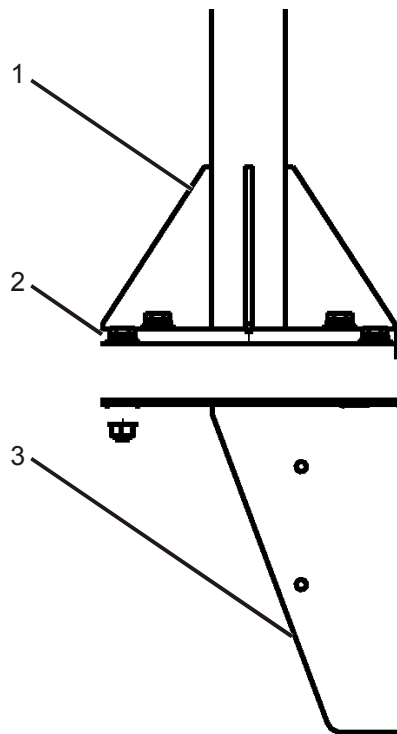

Figure 2-17. Antenna Installation

2.3.2.5 Tuner Installation

(See Figure 2-18)

- a. Place the HLA Tuner (1) on the mounting tray (5) when the HLA tuner connectors facing outside the shelter.
- b. Close the two tuner locks (2) to secure the HLA tuner (1) to the mounting tray (5) (See Figure 2-18).
- c. Open four grounding locks (3) installed on the HLA tuner (See Figure 2-18).
- d. Connect four grounding strips (4) located on the mounting tray (5) to the four grounding locks (3) located on the HLA tuner (1), and tighten the grounding locks (See Figure 2-18).



Figure 2-18. HLA Tuner Installation

2.3.2.6 Tuner Connection

(See Figure 2-19 and Figure 2-20)

- a. Connect strip (1) to the HLA tuner antenna connector (3) using spring washer, flat washer and nut (2) (see Figure 2-19).



Figure 2-19. Strip to Tuner Connection

- b. Cover the antenna connector using the cover (1) (See Figure 2-20).

WARNING

Do not remove the rubber cover. The antenna connector is exposed to high voltage during transmission and the rubber cover protects the operator from electrocution.

Failure to comply may result in injury to personnel.

CAUTION

Do not remove the rubber cover. It protects the equipment from short-circuit during rain.

- c. Connect the other side of the strip (2) to the antenna (above the isolator) (3) using spring washer, flat washer and nut (4) (see Figure 2-20).

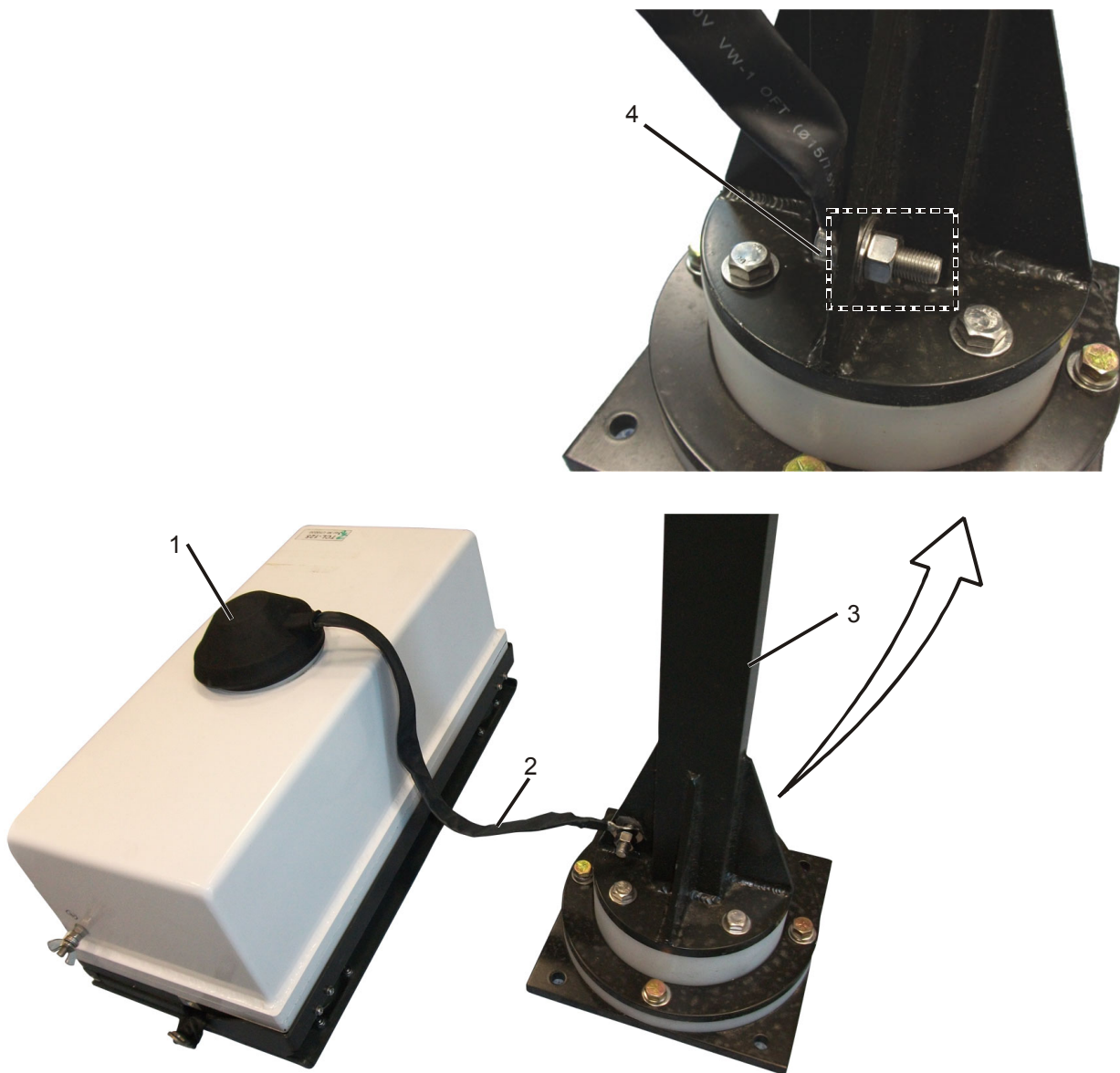

Figure 2-20. Strip to Antenna Connection

2.3.2.7 RT Connection

- a. Connect RF cable connector (CG-2423) to RF connector on the HLA Tuner (see Figure 2-11).
- b. Perform operational test as appears in 2.5.

2.4 HLA-125 TUNER AND HLA SHIPBOARD ANTENNA INSTALLATION

2.4.1 REQUIRED EQUIPMENT

No.	Description	Part Number	Quantity
1.	HLA-125 Tuner	2072-09687-10	1
2.	HLA Mounting	2085-46001-00	1
3.	HLA Shipboard Antenna	2085-09201-00	1
4.	Long Strip	2085-48001-31	1
5.	Rubber cup HLA	2085-43700-00	1
6.	30 m RF cable (CG-2423)	2020-09056-40	1

2.4.2 INSTALLATION PROCEDURE

2.4.2.1 Preparation for Installation (See Figure 2-21)

The antenna creates vertical and horizontal forces during movement of the ship. There for, before antenna installation, a mechanical drawing must be made (schematic) to determine the right way to install the antenna on the ship.

NOTE

A different length of the antenna can be ordered from Elbit, according to the specific dimension of the ship.

For the mechanical design, consult with the ship manufacturer.

A mechanical design and installation can be ordered from Elbit.

- a. Plan the antennas location and the mounting tray location.

NOTE

The HLA tuner can be located inside the structure of the antenna or outside the structure of the antenna.

The distance between the HLA tuner and the isolated leg of the antenna should not exceed 20 cm (the strip length) if the tuner is located inside the antenna structure or 10 cm if located outside the antenna structure.

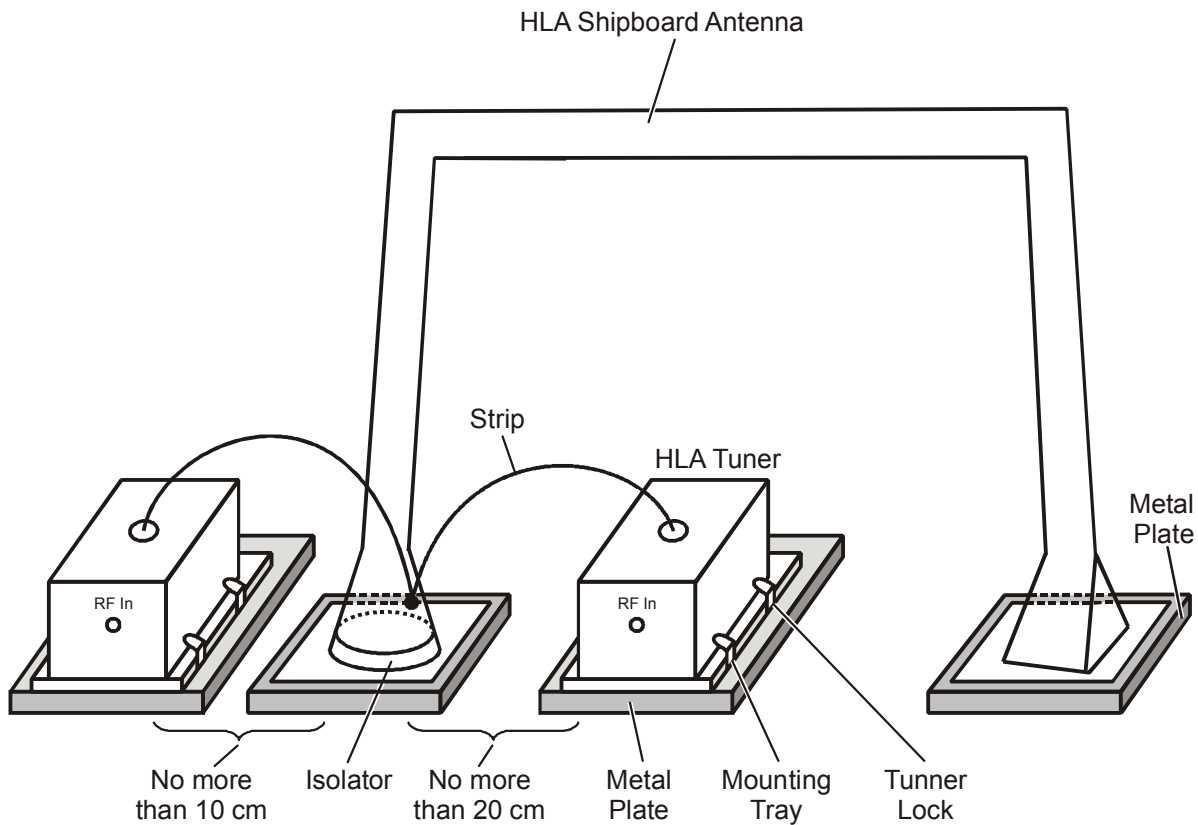

Figure 2-21. HLA Ship Antenna Installation

2.4.2.2 Antenna Connection
(See Figure 2-22 to Figure 2-24)

The antenna is built from four parts; two upper beams and two side beams.

NOTE

The antenna length can be increased using extensions of 0.5 m or 1 m.

- a. Place the four parts of the antenna on the ground (See Figure 2-22).

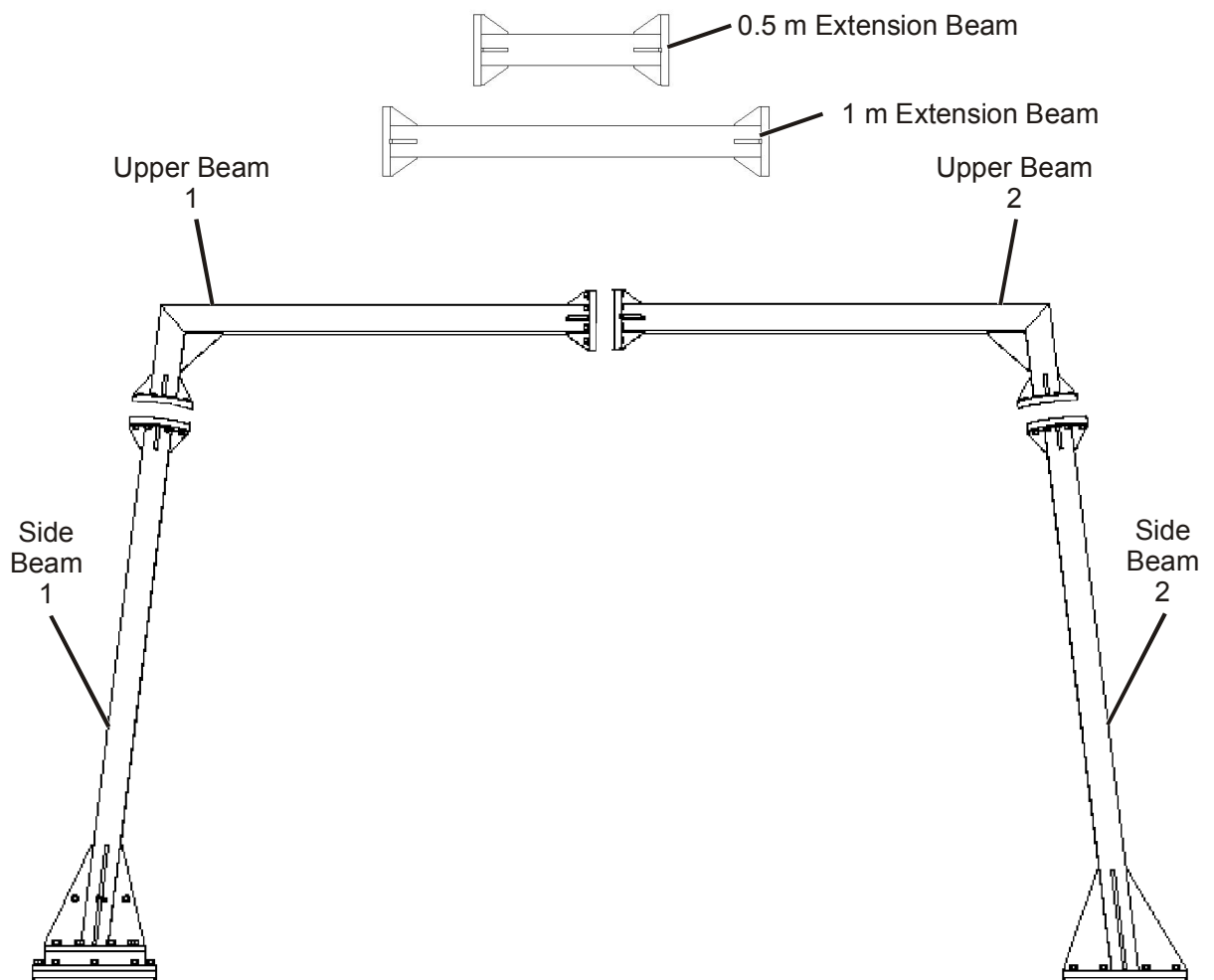

Figure 2-22. Antenna Beam Deployment

- b. Connect the two upper beams (1) to each other using eight bolts, spring washers, flat washers and nuts (2) (See Figure 2-23).

NOTE

Tighten the bolts in a diagonal pattern to increase the connection force.

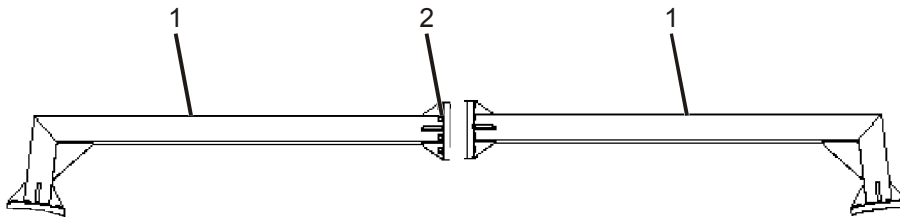

Figure 2-23. Upper Beam Connection

- c. Connect the left beam (2) to the upper beam (1) using eight bolts, spring washers, flat washers and nuts (3) (See Figure 2-24).
- d. Connect the right beam to the upper beam using eight bolts, spring washers, flat washers and nuts (See Figure 2-24).

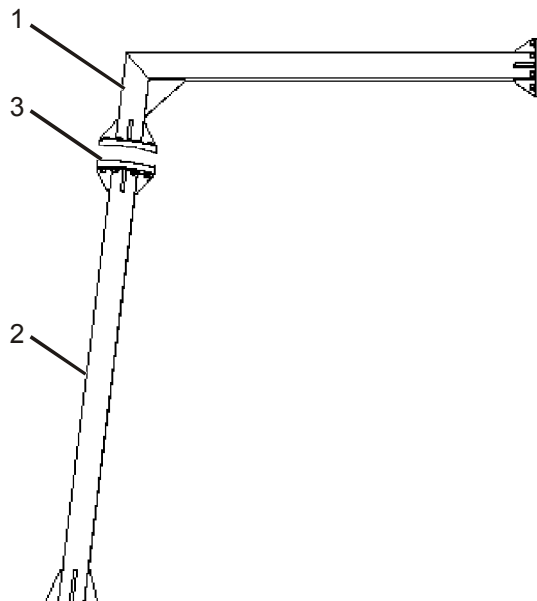

Figure 2-24. Side Beam Connection

- e. Install the metal ring on the isolator.
- f. Install the isolator to side beam 1 leg of the antenna using eight bolts, spring washers, flat washers and nuts.

2.4.2.3 Antenna Installation

- a. Place two metal plates on the ship roof according to the antenna location drawing.
- b. Lift the HLA ship antenna and place it on the two metal plates.
- c. Connect HLA ship antenna to the each metal plate using four bolts, spring washers and flat washers.
- d. Place the antenna on its specific location.

NOTE

Remove the paint from the ship roof at the grounding point location (side beam 2), to enable better connection to the ship body.

- e. Connect each metal plate to the ship using four welding points (for marking).
- f. Remove four bolts, spring washers and flat washers that attach the HLA ship antenna to each metal plate.
- g. Weld the metal plates to the ship roof.
- h. Connect HLA ship antenna to the each metal plate using eight bolts, spring washers and flat washers.

NOTE

Tighten the bolts in a diagonal pattern to increase the connection force.

2.4.2.4 Mountings Installations

(See Figure 2-25)

- a. Place metal plate on the ship roof according to the mounting tray location drawing.
 - b. Verify that the distance between the mounting tray and the antenna mount does not exceed 20 cm or 10 cm according to the position of the mounting tray (see Figure 2-21).
- a. Weld the metal plates to the ship roof.
 - b. Attach the mounting tray to the metal plate using four bolts, spring washers and flat washers (see Figure 2-25).

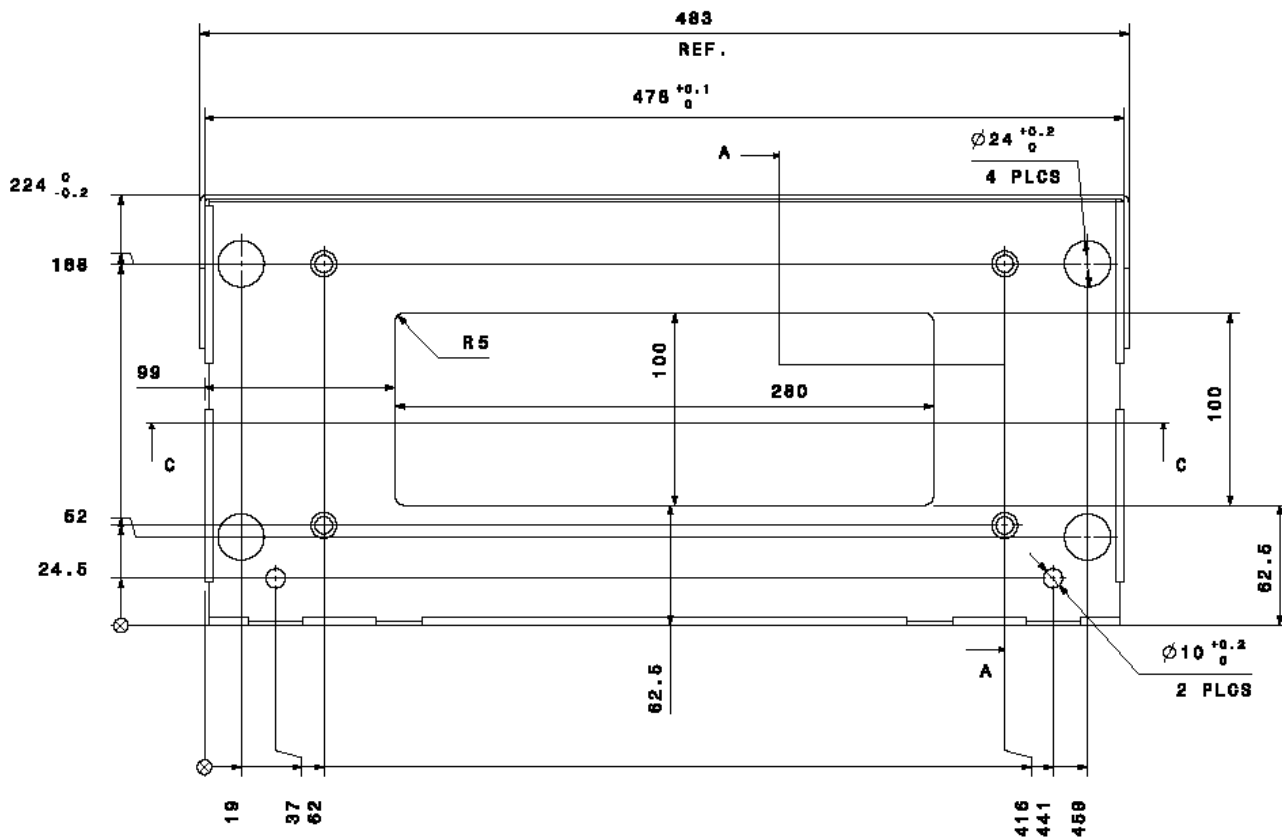

Figure 2-25. Mounting Tray Installation

2.4.2.5 Tuner Installation

(See Figure 2-26)

- a. Place the HLA Tuner on the mounting tray.
- b. Close the two tuner locks (2) to secure the HLA tuner (1) to the mounting tray (5) (See Figure 2-26).
- c. Open four grounding locks (3) installed on the HLA tuner (See Figure 2-26).
- d. Connect four grounding strips (4) located on the mounting tray (5) to the four grounding locks (3) located on the HLA tuner (1), and tighten the grounding locks (See Figure 2-26).



Figure 2-26. HLA Tuner Installation

2.4.2.6 Tuner Connection

(See Figure 2-27 to Figure 2-28)

- a. Connect strip (1) to the HLA tuner antenna connector (3) using spring washer, flat washer and nut (2) (see Figure 2-27).



Figure 2-27. Strip to Tuner Connection

- b. Cover the antenna connector using the cover (1) (See Figure 2-28).

WARNING

Do not remove the rubber cover. The antenna connector is exposed to high voltage during transmission and the rubber cover protects the operator from electrocution.

Failure to comply may result in injury to personnel.

CAUTION

Do not remove the rubber cover. It protects the equipment from short-circuit during rain.

- c. Connect the other side of the strip (2) to the antenna (above the isolator) (3) using spring washer, flat washer and nut (4) (see Figure 2-28).

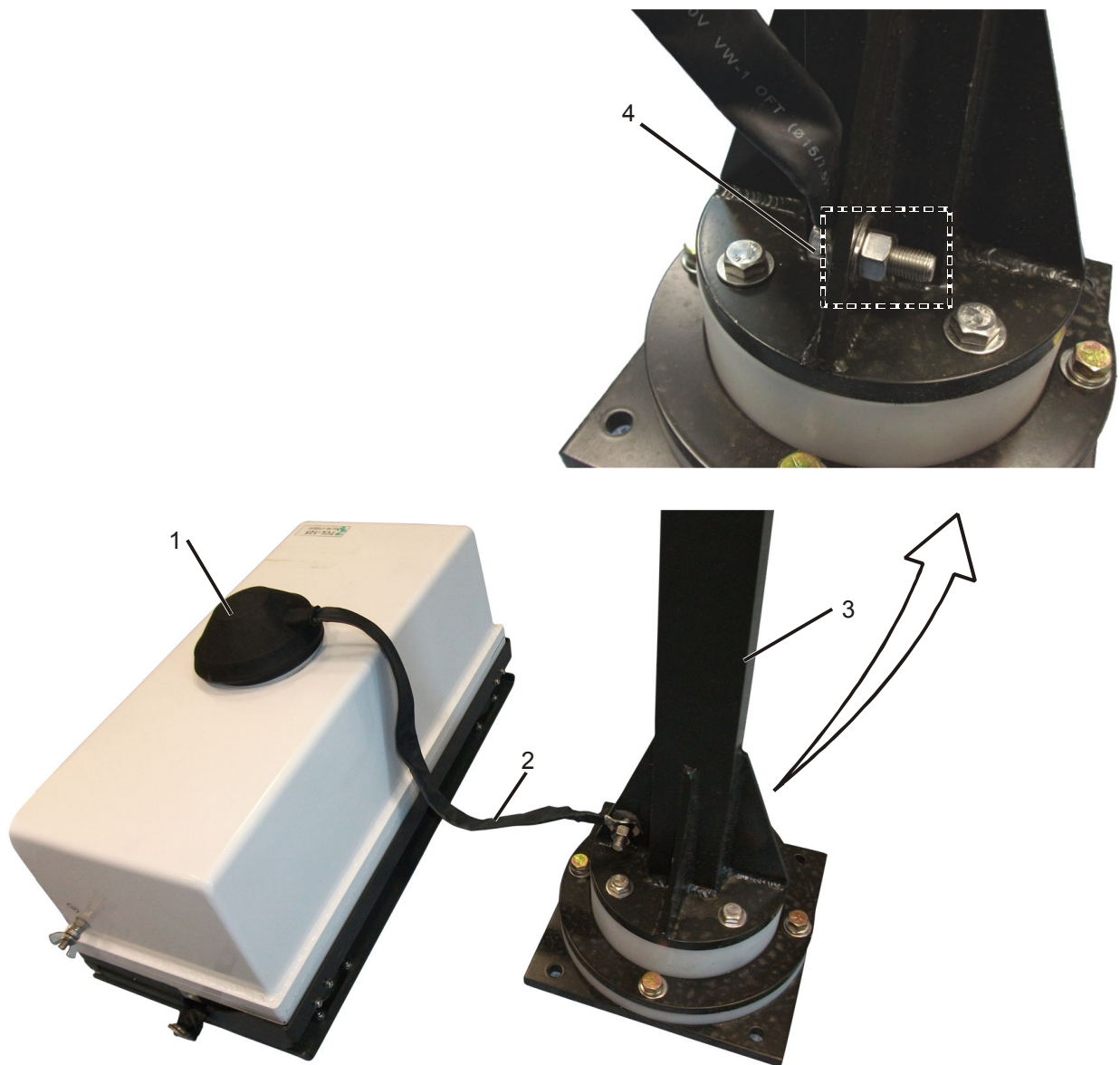

Figure 2-28. Strip to Antenna Connection

2.4.2.7 RT Connection

- a. Connect RF cable connector (CG-2423) to RF connector on the HLA Tuner (see Figure 2-21).
- b. Perform operational test as appears in 2.5.

2.5 OPERATIONAL TEST

- a. Turn On the RT.
- b. Change to “Tuner On”, using the menu.



If the tuning processing takes longer than two seconds, stop the transmission and turn off the RT. Check the antenna connection. Failure to comply may result in damage to equipment.

- c. Change to CW mode, using the menu.
- d. Change frequency and press “Enter”.

Result:

Verify display shows “Tune”.

- e. Press PTT.

Result:

Verify Tx arrow bar is full.



If there are less than 70% Tx bars, stop the transmission and turn off the RT. Check the antenna connection.

- f. Repeat step no. 4 at five different frequencies.